



[Home](#) | [Table of Contents](#) | [List of Chapters](#) | [Committee Members](#) | [Index](#)
[CMES](#) | [CMC](#) | [MCB](#) | [SID](#) | [MLPG I](#) | [MLPG II](#) | [EDEM](#)
[ICCES'05](#) | [Publisher](#)

Advances in Computational & Experimental Engineering & Sciences

**Proceedings of the 2004 International Conference on
 Computational & Experimental Engineering & Sciences**
 ISBN: 0-9657001-6-X

Chapter 1

Advanced Computational Algorithms for Shock,
 Impact, and Penetration Problems

Organizer:

Dr. A.M. Rajendran

[Transient Solution of a Non-Linear Thermoelastic Instability Problem](#)

Abdullah M. Al-Shabibi

[Comparison of Impact between Experimental and Simulation Results in Flexible Elements](#)

Gabriel Emiliano Barrientos; Luis Alejandro Baeza; Rubens Sampaio; Mario Italo Razeto

[Key Issues of Computational Weld Mechanics with Applications](#)

F.W. Brust; J.C. Kennedy

[2-D Analysis of a Building Frame under Gravity Load and Fire](#)

Dat Duthinh

[Characterisation of a Composite Material for Ballistic Protections](#)

Fernando José Ferreira; Mário Augusto Vaz; Francisco Queiros de Melo; Jorge Justo

[On the design and evaluation of lightweight metal protection concepts against blast loading using LS-DYNA](#)

Augustin Gakwaya; Geneviève Toussaint; Patrice Gaudreault; Kevin William; Robert Durocher

[Numerical Evaluation of the Monotonic and Cyclic Behavior of a Welded Beam-to-column Joint](#)

Sandra Jordão; Luis Simões da Silva; Rui Simões

[A Study on the Impact Absorbing Characteristics for Rubber and Metal Layered Structures](#)

Wan-Doo Kim; Dong-Jin Kim; Young-Shin Lee

[Massively Parallel Computations by a General-Purpose Finite Element Analysis Code - IPSAP](#)

Seung Jo Kim; Chang Sung Lee; Jeong Ho Kim; Jin Woo Park

[Lining Load Development Due to Time-Dependent Rock Mass Behaviour](#)

Florian Krenn; Stefan Kainrath-Reumayer; Johann Golser

[Adiabatic Shear Bands in Functionally Graded Particulate Composites](#)

B. M. Love; R. C. Batra

[Dilatation of AD995 Alumina Impacted by Two Consecutive Stress Pulses during a SHPB Experiment](#)

Hui Yang Luo; Weinong Wayne Chen

[Matlab/Simulink Model of a Slip Energy Recovery System in a Cement Plant](#)

Maria Teresa Barroca Outeiro; Eduardo Sousa Saraiva

[Study and Simulation of Fragmentation Phenomena of Concrete Structures Under Stuffy Explosion](#)

Hugues Romero; Franck Jourdan; Frederick Dubois

[Advances in Nonlinear/Linear Computational Dynamics: The Concept of Algorithms by Design](#)

Kumar Tamma

[Scalable Coupling of TFA and Paradyne Analyses for impact Modeling of 3-D Woven Composites](#)

Rama R. Valisetty; Namburu Raju; Rajendran M. Arunachalam; Bahei-El-Din Yahya

Chapter 2

Air Traffic Management Research

Organizer:

Dr. Paul Tan

[Computational Modeling of Trajectory-Oriented Air Traffic Management](#)

Todd J. Callantine

[Non-Parametric Approach to a Paired Data Hypothesis Test in Trajectory Accuracy Analysis](#)

M. M. Paglione

[Virtual Reality in Air Traffic Control Research for US Federal Aviation Administration](#)

Michael A. Pomykacz

[Rapid Prototyping and Exploration of Advanced Air Traffic Concepts](#)

Thomas Prevot; Todd Callantine; Paul Lee; Joey Mercer; Everett Palmer; Nancy Smith

[Modeling Patterns of Performance in Air Traffic Control Operations](#)

Roger W. Remington; Seung Man Lee; Ujwala Ravinder; Benjamin Willems; Michael Freed

[From Concept to Implementation - Modeling and Simulation in Air Traffic Management](#)

A. Schwartz; S. Magyarits

Chapter 3

Biomechanics, Biomolecular Engineering, and Bionanomechanics

Organizers:

Professor Gang Bao, Dr. Huajian Gao, & Dr. I.S. Raju

[Nanostructured Molecular Probes for Gene Detection in Living Cells](#)

Gang Bao

[Knee Ligaments Constitutive Model and Computational Stress Analysis During Walking and Cycling](#)

Constantin Bratianu; Lucian Gruionu

[Microstructure of Round-Hole-Fiber Distribution in Insect Cuticle and Biomimetic Research](#)

Bin Chen; Xianghe Peng; Jinghong Fan

[Flaw Tolerant Bulk and Surface Nanostructures of Biological Systems](#)

Huajian Gao; Baohua Ji; Markus J. Buehler; Haimin Yao

[Remodeling of a Carotid Artery in Response to Flow Overload](#)

C.A. Herrera; X. Lu; Q. Dang; S. Atluri; G. Kassab

[Heterojunctions of Multi-Walled Carbon Nanotubes and Semiconducting Nanocrystals for Electronic Device Applications](#)

Cengiz S. Ozkan

[Hybrid Nanosystems: Their Application in Biology and Engineering](#)

Mihri Ozkan

[Models for Cell Adhesion and Cell Mechanics Applying Micro- and Nanoscopic Tools](#)

Joachim P. Spatz

[Insights into how to Engineer Biomaterials at the Nanoscale](#)

Viola Vogel

Chapter 4

Boundary Element Methods

Organizers:

Professor Jan Sladek & Professor Choon-Lai Tan

[Contact Mechanics and BEM](#)

Ramon Abascal; Jose A Gonzalez

[Recent Advances in the Application of BEM to Damage Tolerance Assessment of Airframe Structures](#)

Ferri M. H. Aliabadi

[Multiwavelet Collocation Boundary Element Solution of Laplace's Equation](#)

Siamak Amini; Rabea Elmazuzi; Steven P. Nixon

[Application of Boundary Element Method to Elasto-plastic Analysis of 2-D Orthotropic Plates](#)

Zhangzhi Cen; Xiushan Sun; Lixin Huang; Yinghua Liu

[Boundary Integral Equations for Thermoelastic Plates](#)

Igor Chudinovich; Christian Constanda

[Frictionless Unilateral Contact by Symmetric Boundary Element Method](#)

Filippo Cucco; Teotista Panzeca; Silvio Terravecchia; Liborio Zito

[Analysis of Interface Crack Problems in Dissimilar Anisotropic Media using the Boundary Element Method](#)

Seila Vasti Faria de Paiva; Paulo Sollero; M. H. Aliabadi; William Portilho de Paiva

[Fast Multipole Accelerated BE Techniques for 3D Stokes Flow](#)

Attilio Frangi; Arturo di Gioia; Giorgio Novati

[Effective Range of V-line Extrapolation Method to Calculate SIF of a Three Dimensional Crack Near to a Surface](#)

Wataru Fujisaki

[Dynamic Crack Interaction in 2-D Piezoelectrics](#)

Felipe Garcia-Sanchez; Andres Saez; Jose Dominguez

[Boundary Integral Equations with the Divergence Free Property for Elastostatics Problems](#)

J. Jackiewicz

[Boundary Element Method for Convective Heat Transfer in a Tall Porous Cavity using Forcheimer Model](#)

Renata Jecl; Leopold Škerget

[On the Continuity of Methods of Fundamental Solutions](#)

Xin Li

[On Fracture Mode Mixity Measures in Interface Cracks. An Application to BEM Analysis of Fibre/Matrix Debonding in Composites](#)

Vladislav Mantic; Federico Paris; E. Correa

[Boundary Element Analysis of Heat Transfer in Anisotropic Functionally Graded Materials](#)

Juan Pablo Nunez; Vladislav Mantic; Federico Paris; John Berger

[Directly Derived Non-Hyper-Singular Boundary Integral Equations I: Petrov-Galerkin Schemes](#)

Zhongyan Qian; Z.D. Han; P. Ufimtsev; S.N. Atluri

[Directly Derived Non-Hyper-Singular Boundary Integral Equations for Acoustic Problems II: The Collocation Implementation](#)

Zhongyan Qian; Z.D. Han; P. Ufimtsev; S.N. Atluri

[On Frictionally Constrained Cracks](#)

Patrick Selvadurai

[2.5D Transient Heat Transfer \(Conduction and Convection\) Using the BEM](#)

Nuno A. V. Simões; António J. B. Tadeu

[Advanced Meshless LBIEM for Thermoelastic Analysis of Non-homogeneous Solids](#)

Jan Sladek; Vladimir Sladek; Chuanzeng Zhang

[Scaled Boundary Finite-Element Solutions for Singular Stress Fields in Multi-Material Wedges](#)

Chongmin Song

[BEM Anisotropic Thermoelastic Analysis of Bi-material Interface Cracks](#)

Choon-Lai Tan; Yui-Chuin Shiah

[Extension of New Local Error Estimators for Panel Methods in 2-D Potential Flow Problems](#)

Marcelo O. Violato; Ariosto B. Jorge; Nelson Manzanares Filho

[Fast Multipole Boundary Element Method for Simulation of Composite Materials](#)

Zhenhan Yao; Haitao Wang; Pengbo Wang

Chapter 5

Composite Materials: Experiments, Analysis, and Applications

Organizers:

Professor David H. Allen, Professor Michihiko Nakagaki,

Professor Anthony M. Waas & Professor Zhenhan Yao

[Experiments on Buckling and Postbuckling Behavior of Laminated Composite Stringer Stiffened Cylindrical Panels](#)

Haim Abramovich; Ariel Grunwald; Pavel Pevsner; Tanchum Weller; Adrian David; Gila Ghilai; Anthony Green; Nisson Pekker

[A Model for Predicting the Evolution of Multiple Cracks on Multiple Length Scales in Heterogeneous Viscoelastic Solids](#)

David H Allen; Chad R Searcy

[Geometric Imperfection Based Design Criteria for Composite Shell Buckling](#)

Damodar R. Ambur; Mark W. Hilburger; Michael P. Nemeth

[Modeling of Damage Growth in Composite Laminates](#)

Shiladitya Basu; Anthony M. Waas; Damodar R. Ambur

[Energetic-Statistical Size Effect in Composites and Sandwich Structures](#)

Zdenek P. Bazant; Alessandro Beghini

[Thermomechanical Wrinkling in Sandwich Panels with a Nonuniform Temperature Distribution](#)

Victor Birman

[Buckling and Postbuckling Behavior of Stringer Stiffened Laminated Composite Curved Panels Subjected to Shear](#)

Chiara Bisagni; Potito Cordisco; Haim Abramovich; Pavel Pevsner

[Residual Strength of Repaired Composite Materials Subjected to Compression Fatigue Loading](#)

R. Carvalho; M. De Freitas

[Contact Buckling and Post-buckling of Delaminated Plates](#)

Herzl Chai

[Mechanics of Atomic Scale Interfaces in Carbon Nanotube Reinforced Composites](#)

Namas Chandra; Sirish Namilae

[Analytical Solution for ITZ's Thickness around Convex Shaped Aggregate Grains based on Section Analysis Method](#)

Huisu Chen; Wei Sun; Piet Stroeven; L.J. Sluys

[The Study of Reversible and Irreversible Impact Loading on Symmetrical and Unsymmetrical CFRP Composite Laminates](#)

Opukuro A. David-West; David H. Nash; William M. Banks

[The Compressive Strength of Fiber Composites](#)

C. K. Hari Dharan; Chun-Liang Lin

[Modelling Postbuckling Composite Structures](#)

Brian G. Falzon; Marco Cerini

[A Crack Along the Interface Between Two Transversely Isotropic Materials - the +/- 45 degree Pair](#)

Yuval Freed; Leslie Banks-Sills

[Analysis of Stress Concentrations in 2x2 Braided Composites](#)

Deepak Goyal; John D Whitcomb

[Response of CFRP Laminates under High Strain Rate Compression until Failure](#)

Rui Miranda Guedes; Fernando José Ferreira; Mário Augusto Vaz; Pedro Henrique Magalhães

[Advanced FRP Composites in the Civil Infrastructure: New Tools for Old Threats](#)

Gilbert A. Hegemier

[Coupled Electro-Stretching-Bending Analysis of Holes in the Electro-Elastic Composite Laminates](#)

Chyanbin Hwu; M.C. Hsieh

[Edge Effects on Sandwich Composites](#)

Moussa Karama; Sébastien Mistou

[Stress Gradient Effects in the Failure Criteria for Textile Composites](#)

Ryan L. Karkkainen; Bhavani V. Sankar

[Delamination Behavior of Composite T-Sections with Z-Fibers](#)

Hakan Kilic; Som R. Soni

[Experimental and Numerical Analysis of Delamination Growth in a Graphite/Epoxy Specimen Caused by a Ply Cut](#)

Manfred Koenig; Ronald Krueger; Edmund Kohler; Manfred Kurz; Thomas Ruckstuhl

[Multi-Objective Optimization of Composite Stiffened Panels: Computations and Experiments](#)

Luca LANZI

[Simulation of Sensor Application and Shape Control of Piezoelectric Structures at Large Deflections](#)

Sven Lentzen ; Ruediger Schmidt

[Homogenisation and Damage Mechanics for a Variety of Layered Systems](#)

L. Neil McCartney

[Characterization of Internal State Variable for Fiber Fracture in UD Composite](#)

Modris Megnis; Povl Brondsted; Saif A. Rehman; Tanveer Ahmad

[Instabilities and Loss of Ellipticity in Fiber-Reinforced Nonlinearly Elastic Solids Under Plane Deformation](#)

Jose Merodio; Raymond W. Ogden

[Finite Element Modelling of Viscoelastic Core Sandwich Panels](#)

Rui Silva Moreira; José Dias Rodrigues

[Composite Material Model with Circular Inclusion under Imperfect Interface Conditions](#)

Michihiko Nakagaki; Ryosuke Matsumoto; Yoshihiro Nakamichi; Shuji Takashima

[Mode II Interlaminar Fracture of Carbon/epoxy Multidirectional Laminates](#)

A.B. Pereira; A.B. Morais; A.T. Marques; P.M.S.T. de Castro

[Composites for Marine Structures - Challenges and Recent Advances](#)

Yapa D.S. Rajapakse

[Design of Composite Layers with Curvilinear Fiber Paths Using Cellular Automata](#)

Shahriar Setoodeh; Zafer Gurdal; Mostafa M Abdalla

[Compression Strength of Textile and Wavy Fiber Composites](#)

Kunigal Shivakumar

[Non-Dilute Multiple Coated Fiber Composites with BCC Microstructures: Effect of Shape and Fiber Orientation](#)

H. M. Shodja; Farshid Roumi

[Environmental Exposure of Glass-fibre Reinforced Composites](#)

Nirvan Karam Sookay; Christopher Julian von Klemperer; Viktor Verijenko

[Modelling of Multi-Layer Damage in Composite Laminates Under Static or Fatigue Loading](#)

C. Soutis; M. Kashtalyan

[A Mechanistic Model for Fatigue Life of Polymer Matrix Composites](#)

Kevin R. Uleck; Anthony J. Vizzini

[Crush Response of Composite Conical Frustrum - Experiments and Modeling](#)

H. Yang; V. Karbhari

[The Electro-Mechanical Response of Electrostrictive Composite Laminates due to Actuation](#)

N. Yu; Y. M. Chang; T. Somphone

Chapter 6

Computational Fluid Dynamics

[Numerical Simulation of a Flow Conditioner](#)

Husam Farag Abdulrahman; Andrea Frattolillo; Nicola Massarotti

[Application of the Advection-dispersion Equation to Characterize the Hydrodynamic Regime in a Submerged Packed Bed Reactor](#)

Antonio Albuquerque; Aderito Araujo; Ercilia Sousa

[Numerical Simulation of Wind Flow in the Vicinity of Forest Block](#)

Tomas Bodnar; Ivo Sladek; E. Gulikova

[Entropic Lattice Boltzmann Models](#)

Bruce Michael Boghosian

[A Fully Coupled Resolution Method for Computing Laminar and Turbulent Flows](#)

E. Didier; A.R.J. Borges

[Finite Element Flow Simulations for Three-Dimensional Incompressible Viscous Fluid](#)

Kazuhiko Kakuda; Naoki Hara

[New Features in the Fluid-Dynamics of Floating Zones Under Marangoni Effect](#)

Marcello Lappa; R. Savino

[An Improved Inverse Design Method for Blades of Finite Thickness](#)

Jose C. Pascoa; Antonio C. Mendes; Luis M.C. Gato

[Simplified Numerical Computation of Flow in Rearing Tank of Marine Fish Larvae](#)

Shigeaki Shiotani; A. Hagiwara; Y. Sakakura; H. Chuda

[Computational Modeling of Gas-Particle Two-Phase Jet by a 3-D Vortex Method](#)

Tetsuhiro Tsukiji; Yohei Yamamoto

Chapter 7

Computational Intelligence and Advanced Info Technologies in Engineering Science & Advances in Imaging

[Extending Workflow Systems with QoS Management](#)

Jorge S. Cardoso

[Public Key Algorithm Comparison](#)

María de Miguel de Santos; Carmen Sánchez Ávila; Raúl Sánchez Reillo

[A Microcalcification Detection System for Digital Mammography using the Contourlet Transform](#)

A. Manzano-Lizcano; C. Sánchez-Ávila; L. Moyano-Pérez

[Generating and Rendering Images Using the X-slits Projection](#)

Nuno Cid Martins; Helder Araújo

[E-learning + ITS + CBR + Simulation a New Perspective of Learning](#)

Nelson Pincho; Viriato Marques; Torres Farinha; António Brito

[New Images from 3D Scanning](#)

João Ramos; Nuno Cid Martins; Fernando Silva

[Villages, Towns and Cities - an E-Government Case Study](#)

Cláudio Jorge Vieira Teixeira; Johnny Santos; Joaquim Sousa Pinto; Joaquim Arnaldo Martins

Chapter 8

Earthquake Structural Engineering

Organizer:

Professor A. Kappos

[Seismic Rehabilitation of an Historical Monument Based on Computational Monitoring](#)

Gabriela Maria Atanasiu; Nicu Curcudel

[Effect of Surface Waves on Dam-Reservoir Interaction During the Earthquake](#)

Reza Attarnejad; Homayoun Zahedi

[On the Seismic Strengthening of Old Masonry Buildings](#)

Rita Bento; M. Lopes; R. Cardoso

[One Dimensional Nonlinear Analysis of Steel Tubular Columns](#)

Masashi Iura; Toshiki Ishizawa

[Derivation of Fragility Curves Using Inelastic Time-History Analysis and Damage Statistics](#)

A.J. Kappos; C.G. Panagiotopoulos; G. Panagopoulos

[Seismic Assessment of a Major Bridge using Modal Pushover Analysis and Dynamic Time-history Analysis](#)

A. J. Kappos; T.S. Paraskeva; A.G. Sextos

[Seismic Rehabilitation of Reinforced Concrete Beam-Column Connections by FRP Material](#)

Athanasios Karabinis; Theodoros Rousakis

[Optimum Translational Vibration of Multi-Storey Buildings with Vertical Mass Axis](#)

Triantafyllos K. Makarios; Chariton Xenidis

[Seismic Response of Piles and Pile Groups in Viscoelastic and Poroelastic Soils](#)

Miguel A. Millan; Jose Dominguez

[Parametric and Harmonic Instability Interaction](#)

Verica Raduka

[Web Shear Deformations of R/C Walls with Flexural Failure Subjected to Cyclic Loading](#)

Thomas N. Salonikios

[Effectiveness of CFRP-Jackets and R/C-Jackets in Post-Earthquake Retrofitting of Beam-Column Subassemblages](#)

Alexander G. Tsonos

[Seismic Behaviour of Infilled Existing RC Buildings](#)

Elizabeth Vintzileou; Christos Zeris; Constantinos Repapis

Chapter 9

Finite Element Analysis in Engineering: Analysis, Design, & Manufacturing

[Numerical Approach to the Evaluation of Calibration Uncertainty of Contact Temperature Sensors](#)

Fausto Arpino; Andrea Frattolillo; Nicola Massarotti

[Computation of the Dynamical Behaviour of Faulty Rotor Systems](#)

Nicolò Bachschmid; Paolo Pennacchi; Andrea Vania; Ezio Tanzi

[Finite Elements Method in Electromagnetism for Actuator Design and Dynamic Behavior Prediction](#)

M. Rosário Alves Calado; Carlos P. Cabrita

[Exact Static Stiffness Matrix for a Deep Beam Embedded in an Elastic Medium](#)

William Paul Howson

[Finite Element Analysis of Elastica](#)

Kyohei Kondo; Koichiro Kuramoto

[Comparation of Accuracy in DEMs at Different Resolutions](#)

Leonor Maria Oliveira Malva

[Numerical Modelling of Soft Soils](#)

Paulo J.V. Oliveira; Paulo A.L.F. Coelho; Luís J.L. Lemos

[Computation of Incompressible Flows with Immersed Bodies on Unstructured Cartesian Grids](#)

Dartzi Pan

Chapter 10

Finite Strain Theory and Cyclic Plasticity

Organizer:

Professor Koichi Hashiguchi

[Mechanical Behaviors of Clay and Sand in terms of Active Soil Skeleton Structure](#)

Akira Asaoka; Toshihiro Noda; Masaki Nakano

[Hardening Behavior of an Aluminum Alloy in Simple Shear](#)

Frederic Barlat; Jeong-Whan Yoon

[Model for Cyclic Simple Shear Behavior of Sands Accounting for Principal Stress Rotation and Finite Strain Deformation](#)

Marte S. Gutierrez

[The Novel Concept "Tangential Relaxation"](#)

Koichi Hashiguchi

[Extended Gradient Plasticity by the Subloading Surface Model with Tangential-relaxation](#)

Koichi Hashiguchi

[Axisymmetric Bifurcation Analysis with Tangential Plasticity](#)

Mehdi Khojastehpour; Koichi Hashiguchi; Yukitaka Murakami

[Finite Element Simulation on Uplift Problem of Ground Anchor](#)

Takashi Okayasu; Koichi Hashiguchi; Toshiyuki Ozaki; Daiki Yajima; Shingo Ozaki

[Elastoplastic Finite Element Analysis of the Trapdoor Problem](#)

Toshiyuki Ozaki; Takashi Okayasu; Koichi Hashiguchi; Daiki Yajima

[Uplift Behavior of Shallow Circular Anchor in Two-layered Sand](#)

Toshinori Sakai; Tadatsugu Tanaka; Saiichi Sakajo

[Formulation and Numerical Post-bifurcation Analysis of Frictional Dilatant Materials at Finite Strains](#)

Keisuke Satoh; Yuki Yamakawa; Yasuyuki Miyaki; Kunio Torii

[Tangential Stress-rate Effect in Soils Subjected to Cyclic Circular Stress Path in the Deviatoric Stress Plane](#)

Hideki Setouchi; Koichi Hashiguchi; Takeshi Shikanai; Takashi Okayasu

[A Two-Surface Plasticity Model for Sands with Variable Degree of Non-Linearity](#)

Mohammed Saiful Alam Siddiquee; Tadatsugu Tanaka

[Cyclic Elasto-plastic Constitutive Model and Finite Element Analysis](#)

Tadatsugu Tanaka

[Non-proportional Loading Behavior of Elastoplastic Solids](#)

Seichiro Tsutsumi; Koichi Hashiguchi; Masahiro Toyosada; Koji Gotoh

[Deformation Analysis of Cohesive Soft Ground with Solidified Surface under Fill Construction](#)

Tetsuji Yoshimaru; Koichi Hashiguchi; Takashi Okayasu; Saiichi Sakajo

Chapter 11

Innovative Aircraft Design

Organizers:

Professor Luigi Morino & Professor Wesley Harris

[Advanced Characterization to Parameterize Material Properties for Multiscale Design](#)

Edoardo Bemporad, F. Carassiti

[From Aeronautical to Nautical Modeling and Design](#)

Paolo Bulgarelli

[From Aeronautics to the Aerodynamic Design of a Formula 1 Car](#)

Ferdinando Cannizzo

[Sequential Multi--Disciplinary Optimization for the Conceptual Design of a Blended--Wing--Body Aircraft](#)

Giampietro Carpentieri; Michel van Tooren; Giovanni Bernardini; Luigi Morino

[Materials Selection in Multidisciplinary-Multiscale Design](#)

Fabio Carassiti

[Technical Note: An Automatic Pilot to Make Perfect Loops Varying only Gflyup through the Loop](#)

José Barahona da Fonseca

[Technical Note II: An Automatic Pilot to Make Perfect Horizontal Loops Varying only Gflyup through the Horizontal Loop](#)

José Barahona da Fonseca

[Technical Note III: The Risk of G-LOC and the Time to G-LOC Meter](#)

José Barahona da Fonseca

[Technical Note IV: Exact Flyup Altitude + Risk of G-LOC= Anti-G-LOC GCAS](#)

José Barahona da Fonseca

[Nanostructured PVD Coatings for Wear and Corrosion Resistance](#)

Stefano De Rossi; Chiara Pecchio; Edoardo Bemporad

[The PrandtlPlane](#)

Aldo Frediani

[Wing Design of a High Altitude and Long Endurance Aircraft](#)

Giuseppe Gatta; Fulvio Romano; Luigi Di Palma; Modesto Pecora

[Aeroelastic Modeling and Vibratory Load Analysis of Helicopters](#)

Massimo Gennaretti; Alessandro Carvai

[Aircraft-based Responsive Launch System for Small Payloads](#)

Michel Kamel

[Life Cycle Cost Multidisciplinary Optimization for Prandtl-Plane](#)

Luigi Morino; Giovanni Bernardini; Daniele De Gregorio; Karen E Willcox; Wesley L. Harris

[A Hermite High--Order Finite Element for Structural Optimal Design](#)

Luigi Morino; Giovanni Bernardini; Chiara Cerulli; Fabio Cetta

[Multi-disciplinary Optimization for the Conceptual Design of Innovative Aircraft Configurations](#)

Luigi Morino; Giovanni Bernardini; Franco Mastroddi

[Aerodynamic Design using Genetic Algorithms and Application to Rotor Blades](#)

Dimitris G. Mourikis; Vasilis A. Riziotis; Spyros G. Voutsinas

[A Model for Solar Powered Aircraft Preliminary Design](#)

Emanuele Rizzo; Aldo Frediani

[Multiscale Features in Surface Engineering: Matching the Appropriate Length Scale for Coating Development and Simulation](#)

Teodoro Valente; Cecilia Bartuli

[Aircraft Design Support using Knowledge Engineering and Optimization Techniques](#)

Michel Van Tooren

Chapter 12

Instabilities and Bifurcations in Fluid Mechanics

Organizers:

Professor Pinhas Bar-Yoseph & Professor Alexander Gelfgat

[Stability and Bifurcation Analyses for Crystal Growth Processes](#)

Pinhas Z. Bar-Yoseph; Alexander Yu. Gelfgat

[The Origin of Complex Dynamics: A Tale of Two Systems](#)

A. Bergeon; E. Knobloch

[Bifurcation of Vortex Breakdown Patterns](#)

Morten Brons; Anders Bisgaard

[From the Hopf Bifurcation to Fully Developed Turbulence in Incompressible Flows](#)

C. H. Bruneau

[The Sequence-of-Bifurcation Approach Towards Understanding Turbulent Flows](#)

Friedrich H Busse

[Thermal Effects on Vortex Breakdown in a Swirling Jet](#)

Jacob Cohen; D. Mourtazin

[Turbulent Dividing Flow on 60° Bifurcations](#)

Nuno P. Costa; Rodrigo Jorge Maia

[Transitions in Thermocapillary Flows: Impact on Crystal Growth](#)

Arne Cröll; Peter Dold; Th Kaiser

[Instabilities of the Flow and the Temperature Field During Crystal Growth of Silicon from Melt](#)

Peter Dold; Arne Cröll

[Non Normal Growth of Counter--Propagating Rossby Waves in Shear Instability](#)

Eyal Heifetz

[Non-Axisymmetric Instabilities in Wide-Gap Spherical Couette Flow](#)

R. Hollerbach

[Multi-Scale Linear Stability Analysis](#)

B. C. Houchens; John S. Walker

[Effects of Gravity Variations on Thermocapillary Convection](#)

S. Hoyas; H. Herrero; A. M. Mancho

[Interconnection Between Spatial and Temporal Instability in a Forced Mixing Layer](#)

Eliezer Kit; Alexander Yu. Gelfgat

[Benard Surface-Tension-Driven Convection in Small Vessels](#)

M. J. Medale; P. J. Cerisier

[Transitions of Flow Between Two Corotating Disks in an Enclosure](#)

Jiro Mizushima; Tomohito Miura

[Convective Oscillations in a Two-Layer System Under the Combined Action of Buoyancy and Thermocapillary Effect](#)

A. A. Nepomnyaschy; I. B. Simanovsky

[Subcritical and Supercritical Bifurcations of the Benney Equation](#)

Alexander Oron; Oded Gottlieb

[Stabilization Effect of a Rotating Magnetic Field on the Flow of a Conducting Liquid in a Cylindrical Container](#)

Janis Priede; Gunter Gerbeth

[Electro-Osmotic Convection in Concentration Polarization](#)

Isaac Rubinstein

[Stability and Bifurcations of the Wake Behind a Ring: A Computational and Experimental Comparison](#)

Gregory J Sheard; Mark C Thompson; Thomas Leweke; Kerry Hourigan

[On the Stability of the Flow Through a Spherical Bulge in a 90° Asymmetrical Bend](#)

J. M.M. Sousa

[Oscillatory Flow of a Two-Fluid System Under Reduced Gravity](#)

Hermann Wilke; Andrew Cliffe; J. A. Pojman

[Vortex Shedding from Elongated Rectangular Plates at Low Reynolds Numbers](#)

Alexander Yakhot; Nikolai Nikitin; Heping Li

Chapter 13

Manufacturing Process Modeling

Organizers:

Dr. Frederick W. Brust, Professor Wen-Hwa Chen, & Professor Hidekazu Murakawa

[Identification of Equivalent Material Constants of a Printed Circuit Board](#)

Kun-Nan Chen; Hsien-Chie Cheng

[Optimal Thermal Design for Chip Placement in Multichip Modules](#)

Wen-hwa Chen; Hsien-Chie Cheng

[Determination of Residual Stress in GTA Multi-pass Welds in Stainless Steel Pipe by Means of Numerical Simulation and Comparison with Experimental Measurement](#)

Dean Deng; Hidekazu Murakawa

[Prediction of Welding Distortion Using Eigen Strain](#)

Hidekazu Murakawa

[Virtual Reality Technology in Civil Engineering: The Wall's Construction Model](#)

Almeida Zita Sampaio; Pedro Gameiro Henriques; Pedro Studer Ferreira

Chapter 14

Mechanics of Geomaterials

Organizers:

Professor A. Tom Scarpas & Professor Patrick Selvadurai

[Geotechnical Properties of Cement Stabilized Oil-Contaminated Soils](#)

Amer Al-Rawas; Hossam Hassan; Ramzi Taha; Abdel Wahid Hago; Bader Al-Shandoudi; Yahia Al-Suleimani

[Plane Cyclic Shearing of a Micro-Polar Hypoplastic Material](#)

Erich Bauer; Jacek Tejchman

[Experimental and Numerical Investigation on the Mechanical Behavior of a Reinforced Sand](#)

Annamaria Cividini; Giancarlo Gioda

[Stress Analysis for a Porous Medium Containing a Cylindrical Rigid Inclusion](#)

Simona de Cicco; Maria Lippiello

[Microstructural Viscoplastic Continuum Model for Asphalt Mixes](#)

Samer H. Dessouky; Shadi Saadeh; Eyad A. Masad; Dallas N. Little

[Analysis of Thermo-Hydro-Mechanical Behaviour of an Unsaturated Geological Barrier](#)

Behrouz Gatmiri; Hasan Ghasemzadeh

[Modelling Concrete Soldier Pile Walls with Geometrical Non-Linearity of Vertical Piles](#)

Nuno Costa Guerra; Manuel Matos Fernandes; António Silva Cardoso; António Gomes Correia

[Coupling Variable Permeability to Strain and Mass Transfer in Contaminated Clays](#)

Tomasz Hueckel

[Using Critical State Theory and Modified Hvem Stabilometer for Modelling Asphalt Material Behaviour](#)

Henny ter Huerne; Martin van de Ven; Andre Molenaar; Martin van Maarseveen

[Ionised Media](#)

Jacques M. Huyghe; Mathieu M. Molenaar

[Reduced Order Implicit Integration Algorithms for Frictional Materials](#)

C. Kasbergen; A. Tom Scarpas

[Development of a Finite Element Tool for Simulation of Ravelling of Asphaltic Mixes](#)

Niki Kringos; A. Tom Scarpas

[Constitutive Modelling of Elastoplastic Response of Sand](#)

Xueyan Liu; A. Tom Scarpas

[Predictions of HMA Permeability Using 3-D Microstructure Simulation of Fluid Flow](#)

Eyad A. Masad; Aslam Al-Omari

[Prototype Behavioural FEM Model for Road Surfacing Seals](#)

T. Milne; M. Huurman; C. Kasbergen; A. Tom Scarpas

[3D Constitutive Model for Unbound Granular Materials](#)

Markus Oeser; Sabine Werkmeister; Bernd Möller; Frohmut Wellner

[Characterization of Road Pavements' Granular Layers by the use of Cyclic Tri-axial Tests](#)

Luis Picado Santos; Rosa Conceição Luzia

[Multi-Phase Material Model for Freezing Damage in Open Graded Asphaltic Mixes](#)

A. Tom Scarpas; Xueyan Liu; Niki Kringos

[On Computational Approaches to Coupling Poroelasticity and Damage Mechanics](#)

Antony Patrick Selvadurai

[Influence of Dilatancy and Elastic Modulus on Simulation of Undrained Behavior](#)

Kiichi Suzuki; Ajitha Wanninayake; Eiki Nakayama; Takeko Mikami

[3-D Network Simulation Technique of Rock Mass Joint and of Analysis of Permeability Tensor](#)

Chunhe Yang; Guibin Wang

[Numerical Simulation of Beach Erosion Due to Storm Wave Actions](#)

Wohua Zhang; Yahua Dai; S. Valliappan

Chapter 15

Meshless & Novel Computational Methods

Organizers:

Professor Carlos Alves, Professor C.S. Chen,
Professor Vitor Leitão, & Professor Thanh Tran-Cong

[Overlapping Communication with Computation in Distributed Parallel FDTD Codes Implemented in Java](#)

C. G. Biniaris; A.I. Kostaridis; D.I. Kaklamani

[Three Dimensional Coupled Analysis of Independently Modeled Substructures by Displacement Welding Technique](#)

Jin Yeon Cho; Jae Mo An; Chang Sik Kim

[Analysis of Structural Dynamic Problems through the Node Activation Technique](#)

Jin Yeon Cho; Sung Woon Woo; Jeong Ho Kim

[A Multi-level Interpolation Method for Solving Elliptic Partial Differential Equations with Variable Coefficients](#)

Csaba Gáspár

[Improved Numerical Approach for the Kansa's Method](#)

Leevan L. Ling; Benny Y.C. Hon

[A Matrix Decomposition RBF Algorithm for solving Large-Scale Problems](#)

Andreas Karageorghis; C.S. Chen; Y.-S. Smyrlis

[Trefftz-Type Sensitivity Analysis for Boundary Value Problem of Poisson Equation](#)

Eisuke Kita; Yoichi Ikeda; Norio Kamiya

[A Locking-Free Meshless Local Petrov-Galerkin \(MLPG\) Formulation for Thick and Thin Plates](#)

Qiuzhan Li; J. Soric; T. Jarak; S.N. Atluri

[Analysis of Crack Tip Stress Using Compactly Supported Meshless Method](#)

T. S. Li; S. M. Wong; K. S. Chan

[On Adaptive Unsymmetric Meshless Collocation](#)

Leevan Ling; Robert Alexander Schaback

[Element-Free Simulation for Non-Newtonian Flows](#)

L. Mai-Cao; Thanh Tran-cong

[An Efficient BEM for Numerical Solution of the Biharmonic Boundary Value Problem](#)

Nam Mai-Duy; Roger Tanner

[Quantum Computation as a New Paradigm for Simulating Physics](#)

Ronald E. Meyers; Keith S. Deacon

[Analysis of Large Deflection Problems of Beams Using a Meshless Local Petrov-Galerkin Method](#)

I. S. Raju

[Diffuse Approximate Method for Casting Simulations](#)

Bozidar Sarler; Janez Perko; Robert Vertnik; Miha Zaloznik

[Solution of Temperature Field in DC Cast Aluminum Alloy Slab by the Diffuse Approximate Method](#)

Bozidar Sarler; Robert Vertnik; Janez Perko

[On the Application of the Meshless Local Petrov-Galerkin \(MLPG\) Method to the Analysis of Shear Deformable Plates](#)

Jurica Soric; Qiuzhan Li; Tomislav Jarak; Satya N. Atluri

[Further Developments on GMLS: Plates on Elastic Foundation](#)

Carlos M. Tiago; Vitor M. A. Leitão

[Meshless Radial Basis Function Scheme for Problems with Boundary Singularity](#)

S. M. Wong; T. S. Li; Y. C. Hon

[Solving Maxwell's Equations by Multiquadrics Method](#)

D.L. Young; T.K. Wong; C.W. Chen

Chapter 16

Multi-scale Modeling of Materials

Organizers:

Professor Fu-Pen Chiang, Professor Z. Xiao Guo,
 Professor Hanchen Huang, Professor Nobutada Ohno,
 Professor Hiroshi Okada, Dr. Deepak Srivastava,
 Dr. Vinod Tewary, Professor Yoshiro Tomita,
 & Professor Priya Vashishta

[A Dynamical Approach to the Spatio-temporal Features of the Portevin- Le Chatelier Effect](#)

G. Ananthakrishna

[Transport Properties of Carbon- and Silicon-Based Nanotubes](#)

Antonios N. Andriotis

[Multiscale Modeling Directly Linking the Electronic Structure Level to the Continuum Level](#)

Tomas Arias

[Toward Efficient Numerical Methods for Solving the Boltzmann Equation for Low-Speed Flows](#)

Lowell Baker; Nicolas G Hadjiconstantinou

[Residual Stress Determination by Diffraction: Modeling and Applications](#)

Davor Balzar; Nicolae C. Popa

[Calculation of Electronic Properties of Point Defects with the Quantum Embedded Cluster Approach](#)

Miguel A. Blanco; Aurora Costales; Víctor Luaña; Ravindra Pandey

[Multiscale Process Modeling in Microelectronics](#)

Max O. Bloomfield; Timothy Cale

[Nanomechanics: Elasticity and Beyond](#)

Tahir Cagin

[Modeling of CNT based Composites: Numerical Issues](#)

Namas Chandra; Chandrakanth Shet

[Micro/Nanomechanics Mapping of Deformation Pattern of Lamellar of TiAl](#)

Fu-Pen Chiang

[Ab-Initio Studies of Large Deformation Processes of Graphene](#)

Peter W. Chung

[Nanotechnology Energetic Material Dynamics Studied with Nanometer Spatial Resolution and Picosecond Temporal Resolution](#)

Dana D. Dlott; Hyunung Yu; Shufeng Wang; Yanqiang Yang; Selezion A. Hambir

[Studies of Defects and Strains Using X-Ray Topography and Diffraction](#)

Michael Dudley

[From Molecule/Surface Interactions to Film Growth: Multi-model Strategy for atomic scale gate dielectrics technologies](#)

Alain Esteve

[Hydrogen Storage on Nanotubes and Nanoscrolls](#)

George E. Froudakis

[Computational Materials at NASA Langley Research Center](#)

Thomas S. Gates

[Elastic Moduli of a Single-Layered Graphene Sheet with Finite Element and Geometrical Approaches Using Equivalent Spring Modeling](#)

Jaafar Ghanbari; Kambiz Behfar; Reza Naghdabadi

[De Novo Multiscale Simulations of Materials](#)

William A. Goddard

[Self-Assembled Semiconductor Nanostructures: Multi-Scale Experimentation](#)

Rachel S. Goldman

[Modelling of Interfaces for Biomedical Devices: Challenges Ahead](#)

Z. Xiao Guo

[Molecular Dynamics Study of Temperature Dependence of Water Flow through Carbon Nanotube Junction using Reflecting Particle Method](#)

Itsuo Hanasaki; Akihiro Nakatani; Hiroshi Kitagawa

[Interface Sliding and Migration in an Ultrafine Lamellar Structure](#)

Luke L. Hsiung

[Atomistic Simulations of Texture Evolution in Thin Films](#)

Hanchen Huang

[How are the Different Structures in Atomic Clusters Formed? - Molecular Dynamics and Experimental Studies](#)

Tamio Ikeshoji

[Role of Atomic Relaxation in Hydrogen-Induced Amorphization](#)

Masahiko Katagiri; Hidehiro Onodera

[Interfacial Heat Flow in Carbon Nanotube Composites](#)

Pawel Koblinski

[Brownian Dynamics Simulation of Polymer Behavior in Nano- and Microfluidic Systems](#)

Satish Kumar

[Crystallographic Effects on Nano-plasticity on Copper Surfaces](#)

Haiyi Liang; Chung-Ho Woo; Hanchen Huang

[Iterative Solution Techniques for the Quasi-continuum Method](#)

Yu Liang; Ramdev Kanapady; Peter Chung

[On Micromechanical Behavior of Glassy Polymer Blended with Different Sized Rubber Particles](#)

Wei Lu; Yoshihiro Tomita

[Homogenized Elastic-Viscoplastic Behavior of Plain-Woven GFRP Composites Subjected to In-Plane Tensile Load](#)

Tetsuya Matsuda; Yuki Nimiya; Nobutada Ohno; Masataka Tokuda

[Molecular-dynamics Study on Crack Growth Behavior Relevant to Crystal Nucleation in Amorphous Metal](#)

Ryosuke Matsumoto; Michihiko Nakagaki; Akihiro Nakatani; Hiroshi Kitagawa

[Micromechanical Properties of Cement Pastes at Elevated Temperatures](#)

Jiri Nemecek; Lubos Kopecky; Zdenek Bittnar

[Microscopic Bifurcation and Post-Bifurcation Behavior of Periodic Cellular Solids](#)

Nobutada Ohno; Dai Okumura; Hirohisa Noguchi

[Surface and Interface Magnetic Structures of Thin Films Studied by X-ray Magnetic Circular Dichroism](#)

Toshiaki Ohta; Kenta Amemiya; Daiju Matsumura

[Applications of Element Overlay Technique to the Problems of Particulate Composite Materials](#)

Hiroshi Okada; Chi-Tsich Liu; Takashi Ninomiya; Yasuyoshi Fukui; Noriyoshi Kumazawa

[Microscopic Bifurcation Analysis for Long-Wave in-plane Buckling of Elastic Square Honeycombs](#)

Dai Okumura; Nobutada Ohno; Takeshi Niikawa

[The Challenge of Modeling Multiple Scales: From DNA to Dislocations](#)

Rob Phillips

[Simulation of Edge Dislocation using Finite Element Method](#)

N. Ramakrishnan

[Designing Nanostructures for New Functional Materials](#)

Bhakta B. Rath

[Reactivity of Oxide Nanoparticles in Aqueous Solution](#)

James Robert Rustad

[From Vibrations to Diffusion in Amorphous Materials](#)

Herbert R. Schober

[Atomic-level Stress Calculation](#)

Shengping Shen; Satya N. Atluri

[Interfacial Conditions in Seamless Multiscale Simulations](#)

Shengping Shen; Satya N. Atluri

[Nanomechanics and Plasticity of Nanotubes and Nanowires](#)

Deepak Srivastava

[Alloy Nanostructure Evolution Via Surface Diffusion](#)

Jerry Tersoff

[Multiscale Modeling of Quantum Nanostructures using Integrated Green's Function and Molecular Dynamics](#)

Vinod K. Tewary; David T. Read

[Multiscale Modeling of Microstructure and Macrostructure Evolution during Sintering](#)

Veena Tikare; Michael V. Braginsky; Jose G. Arguello

[Computational Simulation of Mesoscopic Deformation Behavior of Semi-Crystalline Polymer](#)

Makoto Uchida; Yoshihiro Tomita

[Multimillion Atom Simulations of Nanosystems and Interfaces on Parallel Computers](#)

Priya Vashishta; Rajiv K. Kalia; Aiichiro Nakano

[Atomic-scale Study of Surface-based Nanostructures: Formation and Decay](#)

E.G. Wang

[Effective Properties of Composites Whose Reinforcement has Microstructure](#)

John Whitcomb; Julian Varghese; Jae Noh

[Hybrid Atomistic-Continuum Formulations for Small Scale Hydrodynamics](#)

H. S. Wijesinghe; Nicolas G. Hadjiconstantinou

[Molecular Dynamics / Discrete Dislocation Dynamics Simulations on the Dislocation Behavior in Ni-Based Superalloys](#)

Kisaragi Yoshiro; Yasushi Tabata; Fumiharu Kurose; Yoshihiro Tomita; Hussein M Zbib

[A Finite Element Analysis on the Residual Stresses in a Thin Film/Substrate System](#)

N. Yu; M. A. Jing

[A Micromechanics Model for the Elastic Properties of Carbon Nanotubes](#)

N. Yu; Z. H. Zhang

Chapter 17

Numerical and Analytical Methods in Gradient Elastic Theory

Organizer:

Professor Demos Polyzos

[Wave Dispersion in Concrete due to Microstructure](#)

D. G. Aggelis; T. P. Philippidis; S. V. Tsinopoulos; D. Polyzos

[An Elasticity Solution for Functionally Graded Beams using Stress Function](#)

Mohsen Asghari; Artan Sheshmani

[Elastic-Plastic Modeling of Kinematic Hardening Materials Based on the Corotational Rate of the Logarithmic Strain Tensor](#)

Kamyar Ghavam; Reza Naghdabadi

[Strain-gradient Elasticity: Numerical Methods, a Reciprocal Theorem and a Saint-Venant Type Principle](#)

A. E. Giannakopoulos; E. Amanatidou; N. Aravas

[Size Characterization of Pore Structure for Estimating Transport Properties of Cement Paste](#)

Jing Hu; Piet Stroeven

[On the Numerical Modelling of Orthotropic Large Strain Elastoplasticity](#)

Igor Karsaj; Carlo Sansour; Jurica Soric

[Polyethylene Terephthalate Strips as a Soil reinforcement](#)

Pavel Kuklík; Michal Šejnoha; Jarosla Vacek

[Experimental and Numerical Study of Eccentrically Loaded Normal and High Strength RC Columns](#)

Jiri Nemecek; Pavel Padevet; Zdenek Bittnar

[BEM Solution of 3-D Dipolar Gradient Elastic Problems in Frequency Domain](#)

D. Polyzos

[An Elastoplastic Phase Field Model for Morphological Evolution of Hydrides in Zirconium](#)

San-Qiang Shi; X.N. Jing

[Mechanical Behavior and Structure-Properties Relationships in Amorphous Polymers Simulated by Molecular Dynamics](#)

Ricardo Simoes; Julio C. Viana; Gustavo R. Dias; Antonio M. Cunha

[Bending Design of RC Circular Cross Sections according to ENV 1992 Standard for strains \$\epsilon_{c2} > 1.35\%\$](#)

Matjaz Skrinar

Chapter 18

Optimization & Inverse Problems

[Fire Risk Analysis in Buildings](#)

António Leca Coelho

[A Memetic Algorithm for Operating Room Scheduling](#)

Hongying Fei; Abdelhakim Artiba ; Chengbin Chu

[Life-Cycle Cost Analysis System for Infrastructure Management](#)

Adelino Jorge Ferreira; Gerardo W. Flintsch

[Optimization of FFT Computation for Processors of the Pentium 4 Type](#)

Luis Filipe Figueiredo; Mário Freire

[Shakedown Design of Frames with Constraints on Deformations](#)

Francesco Giambanco; Luigi Palizzolo; Alessandra Caffarelli

[Two-dimensional Thermomechanical Analysis and Optimization of Functionally Graded Materials](#)

Andrew J. Goupee; Senthil S. Vel

[Monitoring Dam Performance through Neural Networks and the Box Jenkins Approach](#)

José Luis Carrasco Gutierrez; Celso Romanel

[Variational Determination of Eigenstrain Sources of Residual Stress](#)

Alexander Michael Korsunsky; Gabriel Regino; David Nowell

[On the Optimization of a Radial Induction Heating Problem](#)

Andrej Kotar; Pino Koc; Boris Stok

[Optimal Dispatch of Hydro Units Considering Head Dependency](#)

Silvio J.P.S. Mariano; Luis A.F.M. Ferreira

[Identification of Thermal Boundary Conditions Using a Transient Temperature History](#)

Kazunari Momose; Yoshikatsu Sawada; Hideo Kimoto

[Simple Procedures to Accelerate Analyses of Large-Scale Models for Sequential Tunnel Excavation](#)

Marcos Noronha; Ch. Duenser; G. Beer

[Range Dependant Tomography of Internal Tides with Relative Arrivals](#)

Orlando Camargo Rodríguez; Sérgio Machado Jesus

[Some Parallel Strategies for an Epidemic Genetic Algorithm to an Inverse Heat Conduction Problem](#)

Sabrina B.M. Sambatti; Haroldo F. de Campos Velho; Leonardo D. Chiwiacowsky; Stephan Stephany; Airam J. Preto

[Fuzzy Optimization of Structures](#)

Wigand Stransky; Bernd Möller; Wolfgang Graf

[Application of the Kalman Filter to Estimate an Elastic Parameter in Order to Improve Controller Performance](#)

Rolf Vargas; L.C. Gadelha DeSouza; Helio K. Kuka

Chapter 19

Structural Integrity, Damage Mechanics & Damage Tolerance

Organizers:

Professor Masanori Kikuchi, Professor Seung Jo Kim,
Professor Toshihisa Nishioka, Dr. Larry Russell,
& Professor Kunigal Shivakumar

[A Conceptual Structural Health Monitoring System for Fatigue Damage](#)

J.D. Achenbach

[Numerical Calculations of the Singular Stress Fields of Failing Mode-II Cracks in Comparison to Experiments](#)

A. Blázquez; J.F. Kalthoff; I. Palomino; A. Fernandez-Canteli

[Predicting Mechanical Properties of Enhanced Performance Concrete Using Compressive Strength](#)

Aires Camões; Barroso Aguiar; Said Jalali

[Law of Void Evolution for Porous Materials](#)

Bin Chen; Z.H. Gao; X.H. Peng; J.H. Fang

[Determining Stiffness Matrix by the Adjoint Method](#)

L.D. Chiwiacowsky; H.F. deCampos Velho; P. Gasbarri

[Dynamic Constitutive Fracture Behavior of Nanocomposites](#)

Victor M. F. Évora; Nitesh Jain; Arun Shukla

[Software for Evaluating Probability-Based Integrity of Reinforced Concrete Structures](#)

Rui M. Ferreira; Said Jalali; Odd E. Gjorv

[Numerical Simulation of Dynamic Elasto Visco-plastic Crack Propagation with](#)

[Wake Zone](#)

Takehiro Fujimoto; Toshihisa Nishioka

[Comparison of Computational Models for Damage-Induced Stress Softening](#)

Zhanqi Guo; Lambertus Johannes Sluys

[Influence of Semi-Rigid Joints on the Behaviour of Steel Beam-Column Structures](#)

Abd-Nacer-Touati Ihaddoudene; Mohamed Chemrouk

[Study on the Thickness Effect of 3PB Specimen on Dimple Fracture Processes](#)

Masanori Kikuchi

[Determination of Crack Initiation Direction from a Bi-material Notch Based on the Strain Energy Density Concept](#)

Jan Klusák; Zdenek Knésl

[Damage Detection with Finite Element Model Updating Using Experimental Modal Data](#)

Andreas Sebastian Kompalka; Stefanie Reese

[Fracture Mechanics of the Interface Crack in a Bimaterial Piezoelectric Wedge under Antiplane Deformation](#)

Thomas Jin-Chee Liu; Ching-Hwei Chue

[Output Only Modal Identification of a Laboratory Model](#)

Filipe Rodrigues Magalhães; Elsa Sá Caetano; Álvaro Ferreira Cunha

[Recent Advances in Hybrid Experimental-Numerical Methods for Dynamic Fracture Studies](#)

Toshihisa Nishioka

[T* Integral Analyses of Shell Structures with Through-Wall Cracks for Nonlinear Deformation Problems](#)

Toshihisa Nishioka; Takako Miyanishi; Takehiro Fujimoto

[Prediction Mode Numerical Simulation for Non-straight Propagation Crack in Elasto-plastic Material](#)

Toshihisa Nishioka; Soichiro Oka; Takehiro Fujimoto

[Numerical Investigation of the Multiple Dynamic Crack Branching Phenomena](#)

Toshihisa Nishioka; Stanislav Tchouikov; Takehiro Fujimoto

[Two-dimensional and Three-dimensional Moving Finite Element Analysis for High-speed Crack Propagation in Brittle Materials](#)

Toshihisa Nishioka; Ken Yamaguchi; H. Furuta; Takehiro Fujimoto

[A Failure Modeling for the Interfaces with Irregular Shape and its Numerical Simulation](#)

Xinrui Niu; Yilan Kang; Shou Wen Yu; Xi Qiao Feng

[Antiplane Stress Analysis of a Non-homogeneous Material Wedge](#)

Yi-Liang Ou; Ching-Hwei Chue

[Shear beams with Indirect Supports - Numerical Modeling and Experimental Assesment](#)

Mário Pimentel; Paulo Cachim; Joaquim Azevedo Figueiras

[Impact Response of Two-Layer Body Armors](#)

Arunachalam M. Rajendran; David J. Grove

[On Convergence of the Series Solution for the Crack Propagation in Stochastically Inhomogeneous Materials](#)

Natalia B. Romalis

[Fracture Properties of a Fire Resistance and Energy Absorbing Core Material](#)

Larry C. Russell; Kunigal N. Shivakumar

[A Total Fatigue Life Model for Composite Laminates](#)

Kunigal Shivakumar; Huanchun Chen

[Validation of Various Linear Spring Stiffness Definitions for a Simple Physical Model for Vibrational Analysis of Cracked Beam Elements Subjected to Uniform Transverse Loads](#)

Matjaz Skrinar; Tomaz Plibersek

[Compressive Instabilities in Woven Textile Composites](#)

Shunjun Song; Anthony M. Waas

[Computational and Experimental Analysis of Acetabular Reinforcement Devices](#)

P.M.A Talaia; C. Relvas; L. Almeida; J. Salgado; Jose Antonio Simoes

[Elastoplastic Analysis of External Axial Surface Cracks in Tubes](#)

Zdenko Tonkovic; Ivica Skozrit

[Charge-Free Zone Model and Failure Criterion for Conductive Cracks in Dielectric and Piezoelectric Ceramics](#)

Tong-Yi Zhang

Chapter 20

Thin and Flexible Structures; Stability & Smart Structures

Organizers:

Professor S.W. Lee & Professor Aditi Chattopadhyay

[Imperfection's Effect of Beam Element for Elastic Buckling Analysis](#)

Redouane Adman; Hamid Afra

[Damage Detection in Electrically Conductive Structures](#)

Damodar R. Ambur; Grady I. Lemoine; Todd A. Anderson

[Remotely Reprogrammable Wireless Sensor Networks for Structural Health Monitoring Applications](#)

Steven W. Arms; Adam T. Newhard; Jacob H. Galbreath; Christopher P. Townsend

[Development of a Novel Optimal Sensor Placement Technique for Structural Health Monitoring](#)

Aditi Chattopadhyay; Santanu Das

[Shape Optimization of Laminated Composite Shell](#)

Maenghyo Cho; Hyoncheol Kim; Hee Yuel Roh; Gun In Kim

[Metal Rubber - Free-Standing, Mechanically Robust Flexible Conducting Materials](#)

Richard O Claus; Jennifer Lalli; Andrea Hill; Bradley A. Davis; Richard Goff

[Reliability Analysis of Structures with Nonlinear Behavior Using Monte Carlo Simulation and Neural Networks](#)

João R de Almeida; Cosmin G Chiorean; João B Cardoso

[Structural Health Monitoring to Detect Fastener Failure](#)

Mark M Derriso; Steve Olson; William Braisted; Martin DeSimio; John Rosenstengel; Kevin Brown

[Smart Actuator for Aeronautical Application](#)

Luigi Di Palma

[Simple Neural Network Application for Traffic Monitoring](#)

Michael Fraser; Linjun Yan; Xianfei He; Ahmed Elgamel; Joel P. Conte; Tony Fountain

[3D Numerical Modeling of Continuity Equations for Abrupt HBTs at the Heterojunction Interface](#)

Antonio J. Garcia-Loureiro; Juan M. López-González

[A Research on Passive Control of Bridge Buffeting based on Multimode Coupling Buffeting Theory](#)

Dajian Han; Xianwu Zeng

[Computational Modeling of Fabric Surface Structure](#)

Seyed Abdolkarim Hossein; Mohammad Ghane

[Assumed Stress-Strain Four-Node Elements Based on the Finite Deformation First-Order Theory of Multilayered Shells](#)

Gennady Mikhailovich Kulikov; Svetlana V. Plotnikova

[Towards Hybrid Equilibrium Models for Large Displacements of Plates](#)

Edward Anthony Maunder; Bassam Izzuddin

[SMA-Activated Nail for the Fixation of Long Bone Fractures](#)

Giuseppe Mirone; Guido La Rosa

[Form and Structural Analysis of High-Rise Pneumatic Structures](#)

Hiroyuki Obiya; Katsushi Ijima; Noriaki Kawasaki; Shin-ichi Iguchi

[Wiener-Haar Expansion of Stochastic Limit Cycles](#)

Chris L. Pettit; Philip S. Beran; Daniel Millman

[An Improved Procedure for the Evaluation of the Lateral-Torsional Buckling Resistance of Unrestrained Steel Beams in Case of Fire](#)

P.M.M. Vila Real; N. Lopes; L. Simões da Silva

[A Numerical Scheme for Post-Buckling Analysis of Thin-Walled Members in the Context of GBT](#)

P. Simão; Luís Simões da Silva

[Geometrical Nonlinear Analysis of Thick Plates with Rotation Fields by using Element-Free Galerkin Method](#)

Yoshitaka Suetake; Masashi Iura; Satya N. Atluri

[Active Vibration Suppression of Sandwich Beams using Piezoelectric Shear Actuators](#)

Senthil S. Vel; Brian P. Baillargeon

[Coupled Vibration of Thin Walled Beams](#)

Gabor M. Vörös

[Buckling of Spring Supported Tapered Columns allowing for Shear Deformation](#)

Andrew Watson; William P. Howson

Chapter 21

Viscoplasticity, Creep, & Damage

Organizer:

 Professor Wolfgang Brocks

[Boundary Layer in Moderately Thick Plates Under Creep-Damage Conditions](#)

Holm Altenbach; Konstantin Naumenko

[Modelling of Anisotropic Ductile Damage Using Gradient Theory](#)

Michael Brünig; Sabine Ricci

[A New Model for Porous Viscoplastic Solids Incorporating Void Shape Effects](#)

Laïla Flandi; Jean-Baptiste Leblond

[A Finite Strain Viscoplastic Law with Anisotropic Damage](#)

Ruocheng C. Lin; Wolfgang Brocks

[Shape Memory Alloy Composites - Modelling of the One-way Effect and the Fatigue Behaviour](#)

Stefanie Reese; Daniel Christ; Klaus Neuking

[Epoxy Resin as a Bonding Agent in Polymer Matrix Composites: Material Properties and Numerical Implementation](#)

Michal Sejnoha; Richard Valenta

Chapter 22

Wave Propagation

Organizers:

Professor Chuanzeng Zhang & Professor Francisco Sanchez-Sesma

[Numerical Determination of Eigenfrequencies and Eigenmodes Using the Method of Fundamental Solutions](#)

Carlos J.S. Alves; Pedro R. S. Antunes

[High Frequency Scattering of Steel Bars with Embedded Cavities via BEM](#)

Julieta Pires Antonio; António Barreto Tadeu

[Inverse Problems for Wave Propagation Studies](#)

Jacobo Bielak

[Boundary Element Formulations Applied to the Analysis of Anisotropic Cracked Plates Under Transient Loads](#)

Eder Lima de Albuquerque; Paulo Sollero

[Elastic-plastic Stress Waves in Ductile-hardening Materials using Finite Element Techniques and a Split-hopkinson Pressure Bar](#)

Fernando José Ferreira; Mário Augusto Vaz; Francisco Queiros de Melo; Joaquim Silva Gomes

[Spectral Element Simulation of Rupture Dynamics Along Planar and Non Planar Faults](#)

Gaetano Festa; Jean-Pierre Vilotte

[Fast BE Calculation of Acoustic Radiation from Vibrating Structures by Mortar Coupling](#)

Lothar Gaul; Matthias Fischer

[Optimal Reduction of Vibrating Substructures](#)

Dan Givoli

[High-Order Absorbing Boundaries for Time-Dependent Waves](#)

Dan Givoli; Vincent van Joolen; Beny Neta

[Dynamic Behaviour of 2.5D Multi-Layered Systems with Elastic and Acoustic Materials](#)

Luis M. C. Godinho; Antonio J. B. Tadeu; Julieta M. P. Antonio

[On Foundations of Ultrasonic Non-Destructive Method of Determination of Residual Stresses in Near-the-Surface Layers of Bodies](#)

A.N. Guz

[Hybrid Numerical Method for Transient Waves in Laminated Cylindrical Shells](#)

Xu Han; G.Y. Li; G.R. Liu

[Transient Behavior of Scattered and Reflected Wave Fields in Anisotropic Solids](#)

Sohichi Hirose; Alan Tan; Chuanzeng Zhang

[Wave Scattering from a Wavy Interface between Two Anisotropic Media](#)

Per-Ake Jansson; Tatiana Krasnova

[Study of Transient Wave Propagation in Plates using Double Pulse TV Holography](#)

Hernani Miguel Lopes; Rui Miranda Guedes; Mário Augusto Vaz; José Dias Rodrigues

[Numerical Solution of the Steady State Propagation of Nonlinear Diffusive Waves](#)

Paula de Oliveira; Ana Paula Mouro

[Approximate 3D Elastodynamic Greens Functions for an Inhomogeneous Elastic Medium](#)

Francisco Sanchez-Sesma; Leonardo Ramirez-Guzman; Francisco Luzon

[Sound Insulation Provided by a Single Wall Separating Dwellings Via BEM](#)

Paulo F. A. Santos; António J. B. Tadeu

[Crack Front Waves on a Shear Crack](#)

John R Willis

[Point Load Generated Surface Waves in a Transversely Isotropic Half-Space using Elastodynamic Reciprocity](#)

Anil C. Wijeyewickrema; Masataka Hattori; Sasikorn Leungvichcharoen

[Transient Analysis of Buried Dynamic Sources in an Anisotropic Elastic Half-Space](#)

Kuang-Chong Wu; Shy-Hour Chen

[Analysis of Elliptical Waveguides by Method of Fundamental Solutions](#)

D.L. Young; S.P. Hu; C.W. Chen; C.M. Fan

[Wave Scattering to the Crack Between Piezoelectric Medium and Substrate or Matrix](#)

Shouwen Yu; Bin Gu; Xuyue Wang

[Wave Propagation Analysis in FGMs](#)

Chuanzeng Zhang; Jan Sladek; Vladimir Sladek; Sohichi Hirose

[Ultrasonic Characterization of the Mechanical Properties of Micro- and Nano-structured Thin Films](#)

Feifei Zhang; Sridhar Krishnaswamy

New features in the fluid-dynamics of Floating zones under Marangoni effect

M. Lappa¹, R. Savino²

Summary

The article presents a discussion of the floating-zone (FZ) problem and of the related three-dimensional flow instability in terms of numerical simulations and prototype applications. The difference between the "half-zone" and the "full-zone" and the related possibility to use one or the other configuration to capture the FZ fundamental hydrodynamics are elucidated. The first bifurcation of the flow is investigated in the case of semiconductor melts for various environments (microgravity and normal gravity) and geometrical parameters (wide ranges of aspect ratio and volume). In the case of Silicon the axi-symmetric flow loses its stability to a steady three-dimensional flow. The model (half or full column) used for the simulations, however, plays a critical role in determining the related azimuthal structure and critical threshold. For $Pr=0.02$ (Gallium) and on-ground conditions, a surprising behaviour is observed. The flow may become unstable directly to an oscillatory disturbance.

Introduction

In the last years increasing interest has been directed towards crystals of semiconductors and towards the crystallisation process of special doped metals and alloys. In fact, single crystals with superior purity and structural quality are needed to support evolutionary progress in material science and computer technology. Current experimentation along these lines is enabling the production of limited quantities of high-quality electronic materials and of materials that exhibit unique properties for use as benchmarks. Within this context, of particular relevance is the Floating Zone (FZ) technique that seems to be one of the best means for obtaining such advanced crystals.

This method has been often used in the terrestrial environment. Additional purity and quality of the specimens however has been obtained in the weightlessness conditions provided by sounding rockets and other orbiting platforms where buoyancy driven convection (which is an important cause of crystal imperfections) is suppressed. Also in absence of gravity however the melt can be

¹MARS (Microgravity Advanced Research and Support Center) Via Gianturco 31 - 80146, Napoli, Italy

²Università degli Studi di Napoli "Federico II" Dipartimento di Scienza e Ingegneria dello Spazio "Luigi G. Napolitano", P.le V.Tecchio 80, 80125 Napoli (Italy).

affected by the presence of another type of convection induced by surface tension forces (the so-called Marangoni flow). This convection is dominant in space and even under normal gravity conditions in situations where the Marangoni flow is emphasised with respect to buoyancy forces (microscale processing). Further improvements in this field require in principle an exhaustive knowledge of the structure of the flow within the melt. For these reasons various models of the FZ technique have been introduced over the last years for capturing the underlying relevant fluid-dynamics in terms of basic flow, related transitions and bifurcations (see Fig.1).

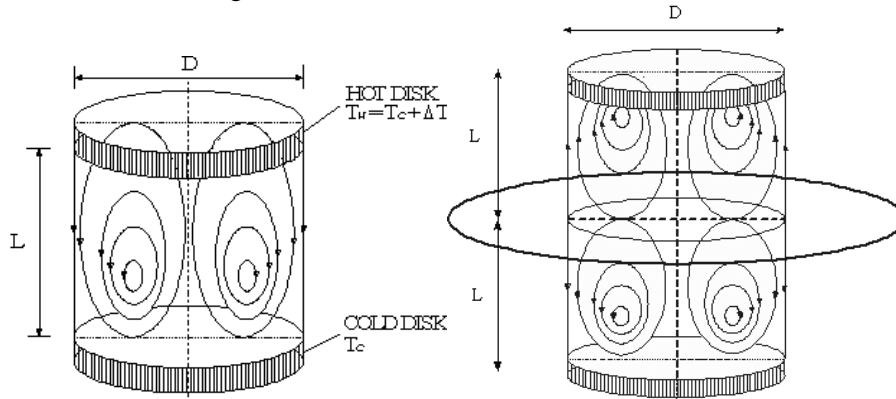

Fig. 1: a) The half-zone and its typical boundary conditions b) The full-zone heated by an equatorial ring heater

The half-zone model simulates half of a real floating zone (the liquid between one of the ends of the domain and the equatorial plane); it consists of a pair of coaxial, differentially heated cylindrical disks with a bridge of liquid material suspended between them (heat flow is neglected through the free surface).

The ends of the full-zone are plane and isothermal as in the case of the half-zone, but the supporting disks are posed at the same temperature (Fig.1b). The presence of a ring heater around the equatorial plane of the zone is simulated imposing a specified heat flux distribution on the free surface with a maximum of the flux in correspondence of the equatorial plane.

The geometrical aspect ratio of the liquid column of full-zone extent (A_F) is defined as $A_F = 2L/D$; the aspect ratio of the corresponding half-zone is defined as $A_H = L/D = A_F/2$ (D is the diameter of the supporting disks). The so-called volume or shape factor is defined as ratio of the volume held between the supporting disks and the volume of the corresponding straight configuration with cylindrical liquid/air interface. The Marangoni number reads $Ma = Re \cdot Pr = \frac{\sigma_r \Delta T L}{\mu \alpha}$ where ΔT is the temperature gradient on the free surface.

Cylindrical interface and microgravity conditions

The major outcome of computations carried out for the full-zone under the constraint of cylindrical interface and zero-g conditions is that for both even and odd critical azimuthal wave-numbers the mirror symmetry with respect to the mid-plane is broken (see e.g. Fig. 2 showing the surface azimuthal velocity).

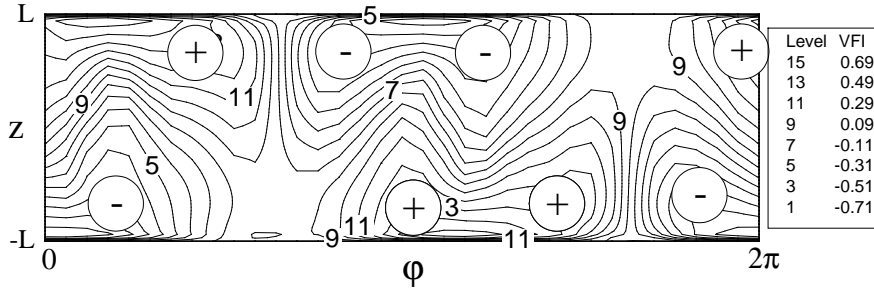

Fig. 2: Surface azimuthal velocity distribution at the 3D stationary state ($A_F=1.3$, $m=1$, $Ma \approx 30$, zero-g).

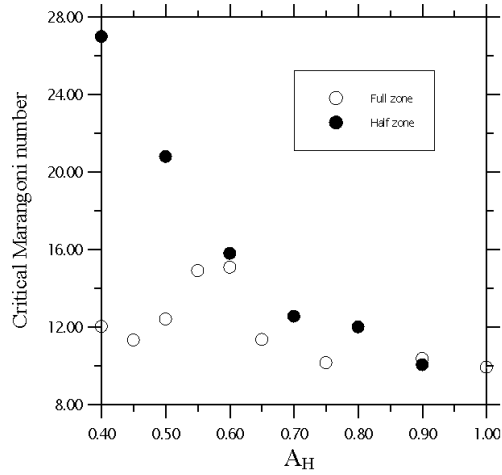

Fig. 3: Comparison between the critical Marangoni number (Ma_{c1} , first bifurcation of the axi-symmetric flow) for the full-zone configuration (Lappa [3]) and available results (Chen et al. [1] and Imaishi et al. [2]) dealing with the half-zone configuration ($Pr=0.01$).

This finding is of paramount importance if one considers that, in the light of this result, the half-zone (supposed to model the flow in a half of the real floating zone under the constraint that this flow is symmetric by reflection about the plane at mid-height between the rods) should not be used to obtain quantitative data about the FZ technique.

The aforementioned symmetry breaking is the main reason for which the Ma_{c1} values computed for the cylindrical half-zone model by several investigators (e.g. Chen, Hu, Prasad [1]; Imaishi et al. [2]) are two times higher than the values recently calculated for the case of full-zone model (see Fig. 3). The flow symmetry with respect to the mid-plane is an additional and relevant part of the problem. It indeed introduces a new degree of freedom. The differences between the two configurations however are not limited to this feature (see below).

Concave and convex volumes in microgravity

It is known (see e.g. Lappa et al. [4]) that in the case of liquid metals and half-zone, for a fixed aspect ratio the critical azimuthal wave-number can be shifted to higher values by increasing S (convex shape) or to lower values by decreasing S (concave shape). The full-zone exhibits a quite different behaviour since the azimuthal wave-number increases in case of deviation from a volume equal to the cylindrical one for both cases $S < 1$ and $S > 1$ (Tables I and II).

Table I: Critical azimuthal wave-number and critical Marangoni number versus the volume of the liquid zone ($Pr=0.01$, full-zone, microgravity conditions).

A_F	L [cm]	$S=V/V_o$	m	Ma_{c1}
1.0	0.5	0.80	4	48.08
1.0	0.5	0.85	3	34.59
1.0	0.5	1	2	12.413
1.0	0.5	1.2	2	6.85
1.0	0.5	1.3	2	10.87
1.5	0.75	1	1	10.15
1.5	0.75	1.2	1	1.454
1.5	0.75	1.4	2	11.53

The new degree of freedom plays a crucial role also with regard to these aspects: In principle each convection roll is bounded by a wall from one side and it is free to interact in non linear way with the opposite convection roll from the other side. It can puff up crossing the mid-plane and protruding in the opposite side of the liquid zone; however this degree of freedom is somehow reduced in the case $S < 1$. In case in fact, due to the concave shape of the free surface, the convection rolls are confined each to the respective half of the full zone configuration (Fig. 3a; this prevents mutual interference and strengthens the constraints for the flow field leading to a larger value of the critical Marangoni number). On the contrary, for $S > 1$ each toroidal roll is free to interact with the opposite roll and to become pervasive throughout the system (Fig. 3b) lowering the stability threshold. Such an interaction is also responsible for the "apparent" doubling of the azimuthal wave number in the mid-plane shown in Fig. 3d.

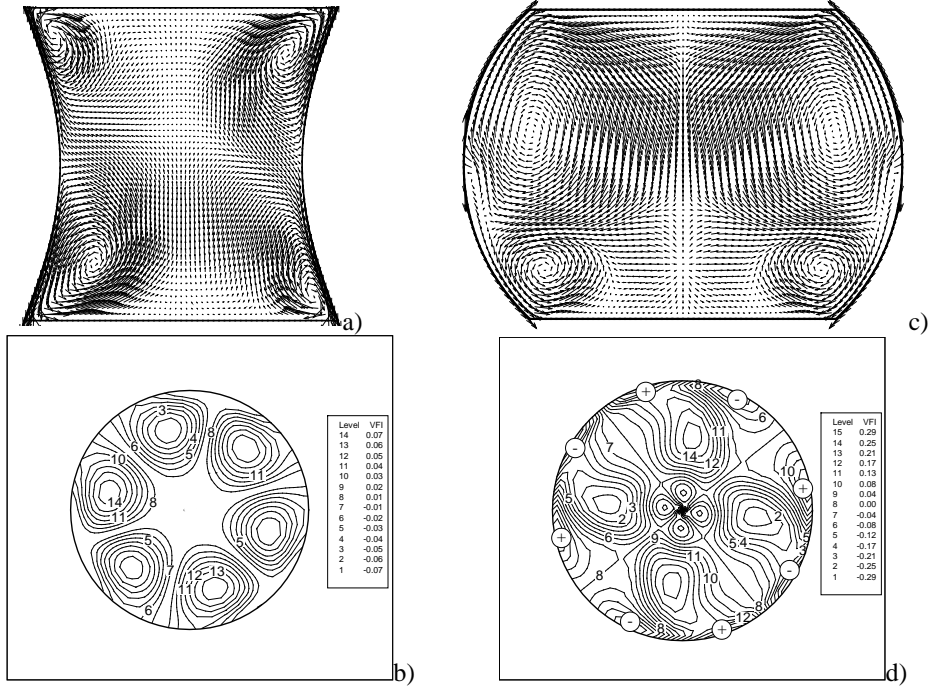

Figs. 3: On the left, structure of 3D Marangoni flow with $m=3$, $A_F=1.0$, $S=0.85$, $Ma=50$, zero-g; (a) velocity field in the generic meridian plane; (b) azimuthal velocity in the equatorial plane. On the right, structure of 3D Marangoni flow with $m=2$, $A_F=1.0$, $S=1.3$, $Ma=25$, zero-g; (c) velocity field in the generic meridian plane; (d) azimuthal velocity in the equatorial plane (the wave number therein seems to be $m=4$).

On ground conditions

Table II: Critical azimuthal wave-number and critical Marangoni number versus the volume of the liquid zone ($Pr=0.01$, full-zone, $L=0.5$ [cm], $A_F=1.0$, on ground conditions, after Lappa [5])

$S=V/V_0$	m	Ma_{c1}
0.80	3	33.24
0.85	3	27.99
0.90	2	12.39
1	1	8.40
1.1	1	3.31
1.2	2	9.54

Comparison between Tables I and II for the case of full-zone gives insights into the effect of gravity on the features of the instability of Marangoni flow. For a

volume equal to the cylindrical one the on ground Marangoni flow is destabilised with respect to microgravity conditions and the azimuthal wave-number is shifted to a lower value. The same trend occurs in the case of $S < 1$; gravity acts destabilising the Marangoni flow. Vice versa stabilisation occurs in the case $S > 1$. For the half-zone, the scenario completely changes. For instance for $S=1$, if the on-ground deformation of the shape is taken into account, gravity always stabilises the Marangoni flow regardless of its direction (parallel or anti-parallel to the axis).

The three-dimensional flow structure is different according to the heating direction (from above or from below). In the latter case, the critical Marangoni number is larger and the critical wave-number is smaller, compared with the opposite condition.

Table III: Critical Marangoni number for the half-zone under normal gravity conditions ($L=1$ [cm], $A_H=1$, $S=1$, Silicon, $Pr=0.01$) after Lappa, Yasuhiro and Imaishi [6].

	Cylinder 1g Heating from above	Cylinder Zero g	Cylinder 1g Heating from below	1g shape Heating from above	1g shape Heating from below
Ma_{c1}	15.36	15.24	14.92	16.62	18.78

The effect of the shape and of the heating condition can be even more dramatic in the case of particular melts for which the deformation is more pronounced than the case of Silicon (for instance Gallium since its surface tension is lower). For the case of Gallium ($A_H=1$, $S=1$ and heating from below condition) in fact the steady bifurcation is suppressed and instability occurs directly in the form of an oscillatory disturbance (Lappa, Yasuhiro and Imaishi [6]).

References

- [1] Chen Q.S., Hu W.R., Prasad V., (1999), "Effect of liquid bridge volume on the instability in small-Prandtl-number half zones", *J. Cryst. Growth*, Vol. 203, pp. 261-268.
- [2] Imaishi N., Yasuhiro S., Akiyama Y., Yoda S., (2001), "Numerical simulation of oscillatory Marangoni flow in half-zone liquid bridge of low Prandtl number fluid"; *J. Crystal Growth*, Vol. 230, pp. 164-171.
- [3] Lappa M., (2003), "Three-dimensional numerical simulation of Marangoni flow instabilities in floating zones laterally heated by an equatorial ring", *Phys. Fluids*, Vol. 15 (3), pp. 776-789.
- [4] Lappa M., Savino R. and Monti R., (2001), "Three-dimensional numerical simulation of Marangoni instabilities in non-cylindrical liquid bridges in microgravity"; *Int. J. Heat Mass Transfer*, Vol. 44, (10), pp. 1983-2003.
- [5] Lappa M., (2004), "Combined effect of volume and gravity on the three-dimensional flow instability in non-cylindrical floating zones heated by an equatorial ring", *Phys. Fluids*, Vol. 16 (2), pp. 331-343.
- [6] Lappa M., Yasuhiro S., Imaishi N., (2003), "3D numerical simulation of on ground Marangoni flow instabilities in liquid bridges of low Prandtl number fluid", *Int. J. Num. Meth. Heat Fluid Flow*, Vol. 13 (3), pp. 309-340.