

# Economic Feasibility Study of using High Temperature Superconducting cables in UK's Electrical Distribution Networks

Weijia Yuan, Sriharsha Venuturumilli, Zhenyu Zhang, Yiango Mavrocostanti and Min Zhang

**Abstract**— This paper details the key outputs of the UK's first feasibility study of implementing the High Temperature Superconducting (HTS) cables in electricity distribution networks to solve capacity issues. This project is mainly aimed to study the technical and economic aspects of using superconducting cables and comparing them with the existing approaches, to determine whether a demonstration project of the superconducting solution is feasible. The University of Bath in collaboration with Western Power Distribution (WPD) has conducted this study, considering a previous capacity issue in WPD's network using both conventional and superconducting solutions.

The first part of the study investigated the different aspects (installation procedures, power capacity, capital and operational costs etc.) of superconducting cables, comparing them with conventional cables. This identified the unique benefit of the high power density of HTS cables which could allow the usage of a Low Voltage (LV) Superconducting cable in place of a High Voltage (HV) conventional cable. In the second part of the study, a 132kV site in WPD's network that required reinforcement has been chosen for performing the feasibility study.

As part of this study, a detailed Cost Benefit Analysis (CBA) was conducted, comparing the superconducting solution with the conventional solution. The outputs from the Present Value (PV) analysis, that has been carried out as part of the CBA are discussed. The results of the CBA power system studies performed are presented, evaluating the impact that each solution has on the network power flows, losses and fault levels. Finally, based on the outputs from the CBA and future projections in the costs of superconducting cables, recommendations were made for the usage of superconducting cables in UK electricity distribution networks to solve network capacity issues.

**Index Terms**—Superconducting cables, WPD, Power grid, Substation, Power transmission, PSCAD.

## I. INTRODUCTION

**S**UPERCONDUCTING CABLES are one of the most plausible industrial applications of superconductivity phenomena. An estimated 8 – 15 % of power losses are said to be incurred

Manuscript received September 19<sup>th</sup>, 2017

Weijia Yuan, Sriharsha Venuturumilli and Min Zhang are with the Department of Electronics and Electrical Engineering, University of Bath, Bath BA2 7AY, U.K. (corresponding author: W. Yuan, e-mail: W.Yuan@bath.ac.uk)

Zhenyu Zhang was with University of Bath, Bath BA2 7AY, U.K. He is now with the Center for Advanced Power system, Florida State University, USA, FL 32310.

Yiango Mavrocostanti is an Innovation and Low Carbon Networks Engineer at Western Power Distribution Ltd., UK.

within the power transmission network [1]. With nearly zero resistance, superconducting cables could be a promising solution, for saving up the power transmission losses. Superconducting cables had already been in usage from a long time, since the discovery of LTS materials. But, the extremely low (<4.2 K) operating temperatures of LTS materials hindered its wide scale application and limited it only towards being used in High-Field Magnets [2]. However, discovery of HTS materials in 1987 changed the scope of entire superconductivity field and its application to a major extent. With high operating temperatures (> 77 K), these HTS materials helped in bringing the application of superconductivity from high field research centers to the wide range of Power and Industrial applications [3].

HTS Superconducting cables have unique properties of high power density and negligible power losses when compared to the conventional cables. With high power densities, these cables made it possible to achieve highly compact, reduced weight and efficient power transfer capabilities. Under normal conditions, these cables transfer power at zero joule heating and electromagnetic radiations, making them a game changer in specific industrial applications like Ship building and Aerospace industries.

With time and technology, the cost of manufacturing HTS tapes has reduced considerably over the last decade, with a scope of much cheaper HTS materials in future [4-7]. This transition created several new opportunities for HTS superconducting cables, which includes replacing the conventional high voltage (HV) cables with low voltage (LV) high power dense superconducting cables in the power grid. To validate the installation, operation and maintenance of these superconducting cables, several demonstration projects have been carried out across the world [8]. These demonstration projects have been of varied lengths, voltage and power ratings, and varied cooling system designs, to show its universal operational capabilities.

THE applicability and reliability of HTS cables have been proven from various HTS cable demonstration projects, however, the usage of superconducting cables in electricity distribution networks needs to be economically feasible to be considered as a solution to capacity problems [9]. The cost of the HTS tape and the necessary cryogenic cooling system currently hinder HTS power devices from being used in the

power grid. The HTS power cables, which have been installed into power grids are typically demonstration projects, which are heavily supported by governmental funding [10]. These demonstration projects are mainly focused on the technical benefits to prove the operating feasibility of HTS cable in the power grid [11, 12]. To the best knowledge of the authors, the comprehensive economic feasibility analysis of using HTS cables in electricity distribution networks is rarely reported.

Based on these considerations, Western Power Distribution (WPD) in collaboration with the Applied Superconductivity Group in the University of Bath, completed a full feasibility study of using superconducting cables in UK's electricity distribution networks to solve capacity issues [13]. The findings of the feasibility study are presented in this paper. Section II surveys the selection of the promising HTS cable installation site, and develops network models to compare the superconducting and conventional cable solutions. Section III analyses quantifiable economic benefits by carrying out a study to understand the viability of installing a superconducting cable, compared to conventional cable solution. Section IV draws some conclusions and learnings for the future works.

## II. PROBLEM STATEMENT & SOLUTIONS OFFERED

### A. Site Selection & Description

The first part of the study showed that, due to the high costs of the superconducting technology, the economic feasibility of using LV HTS cables to prevent the usage of HV i.e. 132kV conventional cables and equipment should be examined, since they are the most expensive general conventional reinforcement solutions. Therefore, in the second part of the study, a 132/11kV site in WPD's network, which required reinforcement was selected for the detailed Cost Benefit Analysis, as shown in Figure 1.

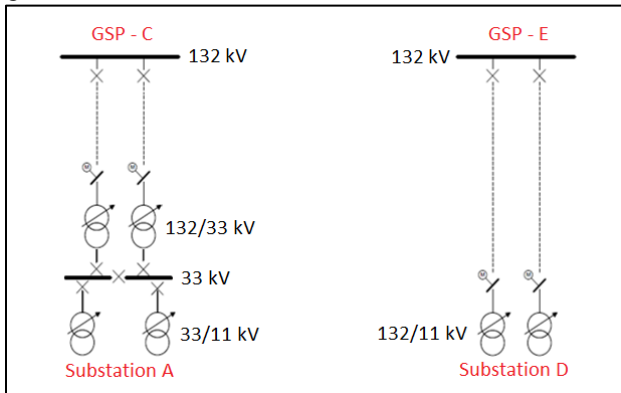

Fig. 1. Selected site before reinforcement.

Substation-A, fed by Grid Supply Point (GSP) – C, is the chosen site for the study, as shown in Figure 1. This site required additional capacity which traditionally would be provided by connecting two additional 132kV infeed points to the site and installing two 132/11kV transformers. The superconducting solution considered in this paper would provide the required additional capacity by transferring the similar amount of power from a neighboring substation with spare capacity (Substation D), using one 11kV superconducting infeed in parallel to a redundant 132 kV conventional infeed

with the relevant auxiliary equipment.

This 132/11 kV site was chosen based on the following criteria: (i) type of site location (urban – limited land availability) (ii) length of required superconducting cable less than 5km (the cost and difficulty of installing the superconducting solution would be high for greater lengths) (iii) high cost of the conventional solution (increasing the need to investigate alternative solutions).

### B. Solutions considered for Reinforcement

Figure 2 demonstrates the Conventional solution of installing two new 132/11kV transformers and the required 132kV infeeds. The capital cost of the conventional solution was estimated at £13.5 million [14].

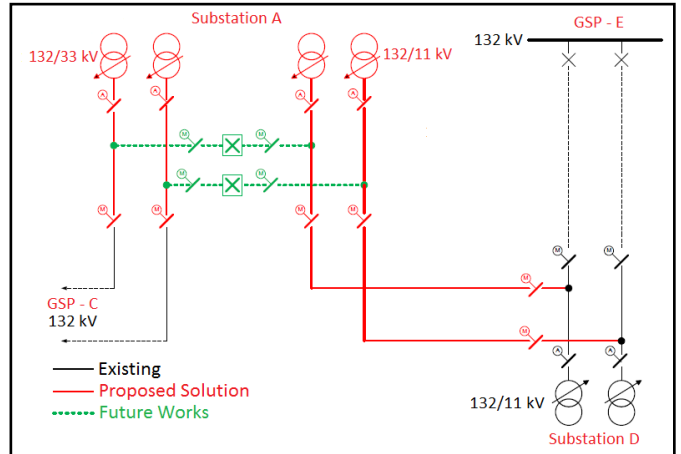

Fig. 2. Selected site with Substation – A being reinforced by the conventional solution.

Figure 3 shows the superconducting solution consisting of one 11kV superconducting infeed and one conventional infeed, ensuring that the solution complies with the Security of Supply Standards defined in Engineering Recommendation P2/6 i.e. N-1 contingency requirement [15]. Based on financial year (FY) 2016-17 prices, the cost of a single superconducting infeed came up to £16.3 million, which includes superconducting cable, superconducting fault current limiter (SFCL), switchgear, cooling system with backup operation, Transportation, Installation and Commission charges. Taking

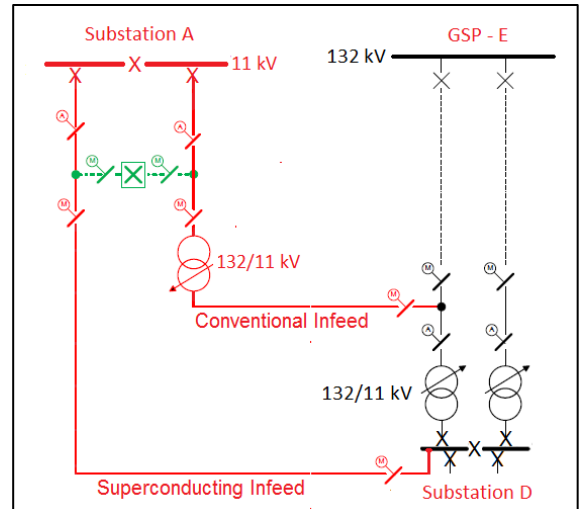

Fig. 3. Selected site with Substation – A being reinforced by the superconducting solution.

into account the redundant conventional infeed, the total cost is estimated as £23.3 million. The residual increase in cost is mainly attributed towards the redundancy requirement of high power transformer and land area for substation, which is nearly half the cost of the conventional solution.

### C. Modelling Results

Equivalent network models have been built in the PSCAD/EMTDC, to model the behavior of each solution and to quantify the losses. The Network parameters used for modelling the conventional solution are provided by WPD, while for the superconducting solution are procured from literature, as shown in Table 1 [16].

TABLE I  
PARAMETERS USED FOR MODELLING

Parameter	Conventional Cable	Superconducting Cable
Resistance	0.03 (Ω/km)	0.0001 (Ω/km)
Inductance	0.36 (mH/km)	0.06 (mH/km)
Capacitance	257 (nF/km)	200 (nF/km)

These models have been evaluated for different loads at various power factors, considering the load fluctuations of substation-A. The load pattern of WPD network being very dynamic across the day, month and year, averaged values of the previous year's load during both summer and winter are used in this particular study. Based on the industry inputs, 30% & 50% loading conditions (i.e. 12 MVA and 20 MVA), each for half the year with a power factor of 0.95, to mimic the average loading behavior of substation-A. Hence, the losses are obtained by integrating the instantaneous losses obtained from PSCAD model for 4380 hrs (i.e. half year duration). With the specified loading conditions, the resistive power losses of each solution have been evaluated as shown in Table 2. Due to the negligible resistance offered by the superconducting infeed, in the superconducting solution, the majority of power is observed to be transferred through the superconducting cable than the parallel placed redundant conventional cable. Thus with negligible resistance, it resulted in very less losses compared to conventional solution, as shown in Table 2.

TABLE 2  
LOSSES EVALUATED (ANNUALLY)

Parameter	Conventional Solution	Superconducting Solution
Resistive losses	928.55 MWh	798.91 kWh
Operating losses	0	350 MWh

For the superconducting solution, the operating losses shown in Table 2 are quantified based on the power supply required for the cooling system. As conventional solutions, do not involve any such operating losses, they have been considered to be zero.

### III. ECONOMICAL COMPARISON OF SOLUTIONS

It has been well known that superconducting cables are more expensive than conventional cables [10]. In this study, to perform a complete economic feasibility analysis, the Present

Value (PV) of both the solutions over their entire life span has been studied taking into account both the capital and operating costs. It should be noted that in this economical study only the capital cost, operating cost and losses are considered, while the maintenance cost and profits made on power transmission, have been neglected and assumed to be same for both solutions. Other unquantifiable cost for the superconducting solution such as smaller right-of-way, no electromagnetic field pollution, etc., are not included as they cannot be easily quantified within the duration of the project.

#### A. Present Value (PV)

Based on the value of money w.r.t. time, money in the present is worth more than the same amount in the future. This is because earnings could potentially be made using the money invested during the time period considered and because of inflation and interest. In other words, one pound earned in the future will not be worth the same as one earned in the present. To include this concept, the following equation is adopted in the present value calculation.

$$PV = \text{Capital cost} + \sum \frac{FV_n}{(1+i)^n}$$

$$FV_n = \text{Losses}_n + \text{Operating cost}_n$$

#### B. Losses and Operating Cost estimation

The power transmission losses were quantified in terms of cost. For that, the cost of losses determined by the Ofgem, has been used as a standard [17]. To determine the operating cost of the cooling system, the price of electricity at which DNO's are charged has been utilized to determine the operating cost [18].

$$\text{Operating cost} = \begin{cases} 0 & \text{for Conventional cable} \\ \text{Cooling cost} & \text{for Superconducting cable} \end{cases}$$

TABLE 3  
COST OF LOSSES AND OPERATION (PER ANNUM)

Parameter	Conventional Solution	Superconducting Solution
Power losses (@ 4.8p/kWh)	£44,570.88	£38.35
Operating losses (@ 9.7p/kWh)	0	£33,954.28

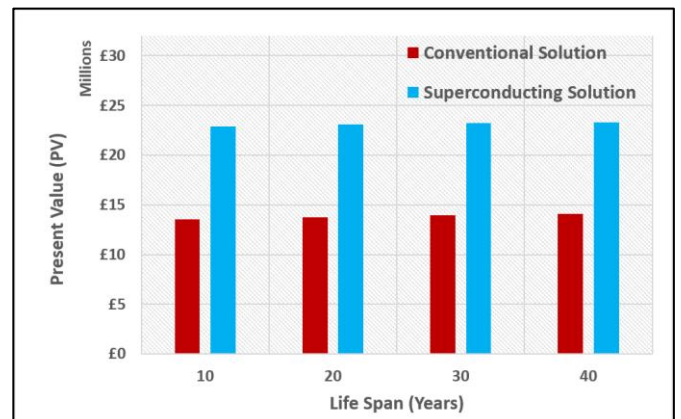

Fig. 4. Present Value (PV) of cost over entire lifetime.

### C. Time Span

Dielectric failure determines the life time of the cable. For conventional cables, with latest improvise, the life time is determined to be nearly 40 years. While, there exists no such long term operating superconducting cable, to quantify the life span. Hence, to make it simple, similar lifetime has been used for superconducting cables to evaluate the PV.

Given the case study, as seen in Figure 4, the Superconducting solution is nearly 75% more expensive than the conventional solution for all life spans considered. Thus the current capital cost of the superconducting solution is still a big hurdle for electricity distribution networks to adopt this technology for the case studied.

### D. Future Cost Prediction

Since the study has shown that using superconducting cables in electricity distribution networks to solve capacity issues is currently 75% more expensive than the conventional solution, it was of interest to examine the changes required in the market in the future to make such an implementation realistic in terms of costs.

With the increasing demand for superconducting applications, the cost of HTS materials is predicted to decrease in the future [5-7]. Over the last decade Superconducting materials saw a consistent decrement in its cost at an average rate of 10% [4]. Considering this decrement to be consistent over the next decade, the future cost of the superconducting solution has been estimated and compared with the conventional solution costs of the case study. As shown in Figure 5, if superconducting material costs keep decreasing by 10% every year, the cost of the 5km superconducting solution could be comparable to the conventional solution in 10 years.

Similarly, the ratio of superconducting solution to the conventional solution cost is observed to decline with the reduction in length of the solution. Considering this fact, a feasibility analysis, similar to the one shown in figure 5 has been carried out for varied lengths. The results are very interesting, with the 2 km superconducting cable solution being cheaper than that of conventional solution within the next 5 years duration, as seen in figure 6. Similarly, cable solutions of 3, 4, 5 km length have also been studied and are observed to match the conventional solution's costs in the next 10 years,

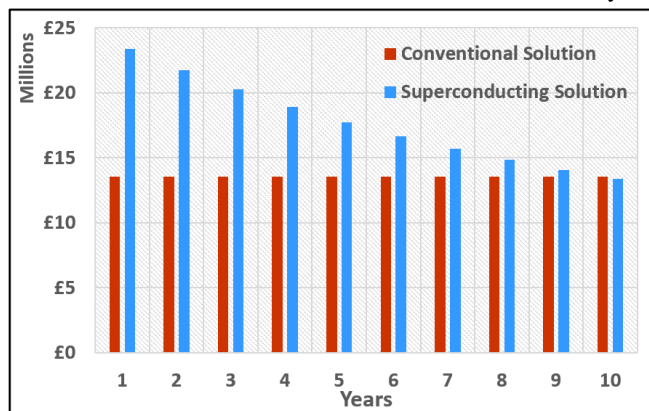

Fig. 5. Forecasted price of superconducting solutions and its comparison to the conventional solutions.

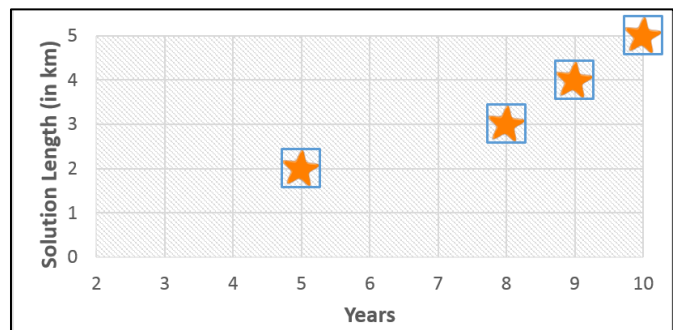

Fig. 6. Feasibility of varied length solutions over the next 10 years.

showing the strong prospects of superconducting cable solutions.

### E. Land Required

One of the main benefits of the superconducting solutions is that the land area required is significantly less than the area needed for the conventional solution. Therefore, the study has examined the land area requirements for each type of solution as shown in Table 4. In cases where land availability is the main constraint and there are no other solutions available, superconducting solutions could be the only alternative.

TABLE 4  
LAND AREA REQUIRED

Solution Type	Area (Sq.mts)
Conventional Solution	3,500-4,000
Conventional + Superconducting Solution	2,000-2,500
Complete Superconducting Solution	150-200

## IV. LEARNINGS & CONCLUSIONS

This paper presented the findings from the first feasibility study examining the usage of superconducting cables in UK electricity distribution networks to solve capacity issues. Considering the case study of using superconducting cables to solve capacity issues at a 132/11kV site, it was shown that the superconducting solution is 75% more expensive than the conventional solution. Therefore, in this case, the cost of the superconducting solution is preventing its implementation in electricity distribution networks. As part of the analysis completed to examine the changes required in the market to make superconducting solutions more economically feasible, it was found that if prices of superconducting materials keep dropping by 10% every year, the costs of the 5km superconducting solution will be comparable to the conventional solution in 10 years, and for the 2, 3 and 4 km cases in 5-9 years duration. The overview of the land area requirements of each solution has shown that the superconducting solution requires significantly less land, thus highlighting its unique benefits, where the availability of land or space is very limited.

### ACKNOWLEDGMENT

This work has been carried out by the University of Bath in collaboration with WPD. The author would like to thank all the industry partners, without whom it would have been impossible to complete this feasibility study.

## REFERENCES

- [1] I. E. Commission, "Efficient Electrical Energy Transmission and Distribution," *Report, Switzerland*, 2007.
- [2] Bauer, P.; Ambrosio, G.; Andreev, N.; Barzi, E.; Dietderich, D.; Ewald, K.; Fratini, M.; Ghosh, A.K.; Higley, H.C.; Kim, S.W.; Miller, G.; Miller, J.; Ozelis, J. and Scanlan, R.M., *Fabrication and Testing of Rutherford-Type Cables for React and Wind Accelerator Magnets*, **IEEE Trans. Appl. Supercond.**, **11** (1), 2457-2460 (2001)
- [3] "High Temperature Superconductor Degaussing System Technology Development." Fitzpatrick, B., Fikse, T., Robinson, M., 2005, pg. 1-10.
- [4] Selvamanickam, V. and Dackow, J. "Progress in Superpowers 2G HTS wire Development and Manufacturing", presented for US DOE peer review – Advanced cables and conductors program – June 29 – July 1, 2010.
- [5] Matias, Vladimir, and Robert H. Hammond. "HTS superconductor wire: \$5/kAm by 2030?." *CCA 2014 (Seoul, Korea, 30 November–3 December)* (2014).
- [6] Grilli, Francesco, and Anna Kario. "How filaments can reduce AC losses in HTS coated conductors: a review." *Superconductor Science and Technology* 29, no. 8 (2016): 083002.
- [7] Morandi, Antonio. "HTS dc transmission and distribution: concepts, applications and benefits." *Superconductor Science and Technology* 28, no. 12 (2015): 123001.
- [8] C. S. Weber, R. Lee, S. Ringo, T. Masuda, H. Yumura and J. Moscovic, "Testing and demonstration results of the 350 m long HTS cable system installed in Albany, NY", *IEEE Trans. Applied Superconductivity*, Vol. 17, No. 2, pp. 2038-2042, 2007.
- [9] Stemmler, Mark, Frank Merschel, Mathias Noe, and Achim Hobl. "AmpaCity—Installation of advanced superconducting 10 kV system in city center replaces conventional 110 kV cables." In *Applied Superconductivity and Electromagnetic Devices (ASEMD), 2013 IEEE International Conference on*, pp. 323-326. IEEE, 2013.
- [10] Yang, Byeongmo, Jiwon Kang, Seungryul Lee, Changlyul Choi, and Younghyun Moon. "Qualification and Demonstration of a 80 kV 500 MW HTS DC Cable for Applying into Real Grid."
- [11] Masuda, T., H. Yumura, M. Watanabe, H. Takigawa, Y. Ashibe, C. Suzawa, T. Kato et al. "Design and experimental results for Albany HTS cable." *IEEE transactions on Applied Superconductivity* 15, no. 2 (2005): 1806-1809.
- [12] S. Pamidi, C. H. Kim, L. Graber, "High-temperature superconducting (HTS) power cables cooled by helium gas", in *Superconductors in the Power Grid: Materials and Applications*, C. Rey, Ed. Cambridge, UK: Woodhead Publishing Ltd., pp. 225-260, 2015.
- [13] Zhenyu Zhang, Sriharsha V, Min Zhang and Weijia Yuan, 'Superconducting cables – Network feasibility study, Work Packages 1-3', WPD, 2016-17. <https://www.westernpower.co.uk/Innovation/Projects/Closed-Projects/Superconducting-Cables.aspx>; Accessed on: 16 Jan 2018.
- [14] Based on the internal discussion and data provided by WPD.
- [15] Energy Networks Association, Engineering Recommendation P2/6 – Security
- [16] J. Howe et al., Very low impedance (VLI) superconductor cables: Concepts, operation implications and financial benefits, white paper, Nov. 2003
- [17] Veaney, J., "Energy Efficiency Directive: An assessment of the energy efficiency potential of Great Britain's gas and electricity infrastructure", Ofgem.
- [18] "Gas and electricity prices in the non-domestic sector", Department for Business, Energy & Industrial Strategy, 2016.